

Argos1600
Multi-image System
Control Software

User Manual

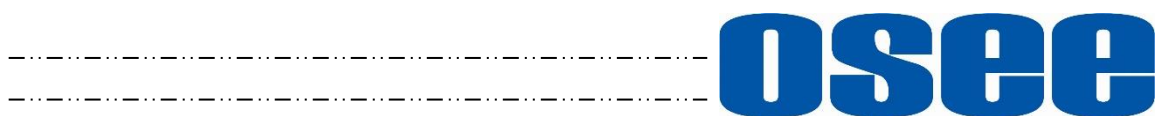

Product Information

Model: Argos Controller Software
Version: V010000
Release Date: October 25th, 2022

Company

OSEE TECHNOLOGY LTD.

Contact Information

Address: No.22 Building, No.68 zone, Beiqing Road, Haidian District,
Beijing, China
Post Code: 100094
Tel: (+86) 010-62434168
Fax: (+86) 010-62434169
Web: <http://www.osee-dig.com.cn/>
E-mail: sales@osee-dig.com

About this manual

Important

The following symbols are used in this manual:

Tips

- The further information or know-how for described subjects above which helps user to understand them better.
-

Warning

- The safety matters or operations that user must pay attention to when using this product.
-

Contents

The user manual applies to the following device types:

- ❖ **Argos1600-12G-16**
- ❖ **Argos1600-3G-16**

The images of Argos multi-image system editor are adopted in the following descriptions.

Any of the different specifications between the device types are elaborated. Before reading the manual, please confirm the device type.

Contents

Contents	I
Chapter 1 Overview	1
Chapter 2 Startup and Software Interface	3
2.1 Device Connection	3
2.2 Startup Argos	4
2.3 Software Interface	7
2.3.1 SYSTEM Configuration Window	8
2.3.2 Input Configuration Window	11
2.3.3 Layout Configuration Window	12
Chapter 3 Functionalities and Operations	19
3.1 Basic Function	19
3.1.1 Login and User Management	19
3.1.2 Add Device	21
3.1.3 Device Connection	25
3.2 System Configuration	27
3.2.1 Add Device	27
3.2.2 Device Settings	28
3.2.3 Save Device	33
3.2.4 Device Edit	33
3.2.5 Device Backup and Import	34
3.2.5.1 Backup	34
3.2.5.2 Import	35
3.3 Input Configuration	36
3.3.1 Set Source Name	38
3.3.2 Set Audio Source	39
3.3.3 Set UMD	40
3.3.4 Alarm Setting	42
3.4 Layout Configuration	47
3.4.1 Template Configuration	48
3.4.1.1 Create a Template	48
3.4.1.2 Save a Template	49
3.4.1.3 Open a Template	51
3.4.1.4 Delete a Template	51
3.4.1.5 Model Properties	52
3.4.1.6 Other Operations to Template	54
3.4.1.7 Preset Templates	59

3.4.2 Tool Bar	61
3.4.3 Elements Properties	61
3.4.3.1 Monitor	63
3.4.3.2 Clock/Date	70
3.4.4 Elements Layout	75
3.4.4.1 Add an Element Window	75
3.4.4.2 Select an Element Window	77
3.4.4.3 Split	78
3.4.4.4 Adjust Window	79
3.4.4.5 Common Edit Operation	82
3.5 Other Functions	84
3.5.1 Restore Factory Default	84
3.5.2 Language	84
3.5.3 Hardware Update	85
3.5.4 About	88
3.6 Linkage With the Supervisory Monitor	88

Chapter 1 Overview

Argos serial processors are controlled using Argos control software which is running in the remote control computer using Windows system software. Argos is simple to use and easy to learn, through its use of simple drag and drop control.

The Argos controller and its inner control software compose the Multi-view system, the device integrates an internal control software to connect to and configure the controller. You can configure multi-windows and multi-scene with the input video sources, and set them at any position and in arbitrary size in the operating interface of the software. Each video window has adequate resolution to show high quality frame effects. The software is a WYSIWYG editor and easy to use.

It is widely used in the following fields: educational and research, public announcement, publication and information, administrative management, military command system, exhibition and presentation, security surveillance system, appliances sales etc.



Figure 1 A Diagram of Display Wall

Features

- Image can be displayed anywhere, any size, within or cross screens. The window of a video source can be moved from one screen to another screen in real time.
- Supports various customized scene models, including position, size and stacked relationship of the input video windows.
- Support several types of timers: analog clock timer, digital clock timer, countdown timer, and digital data timer.
- Supports MARKER, UMD, TALLY, MET display

Chapter 2 Startup and Software Interface

2.1 Device Connection

1. Multi-image Processor and Lines

According to the customer's requirements, connect the signal sources with the input interfaces, and connect the signal outputs to the target display screens. The Argos1600 configured is as shown in **Figure 2.1.1**.

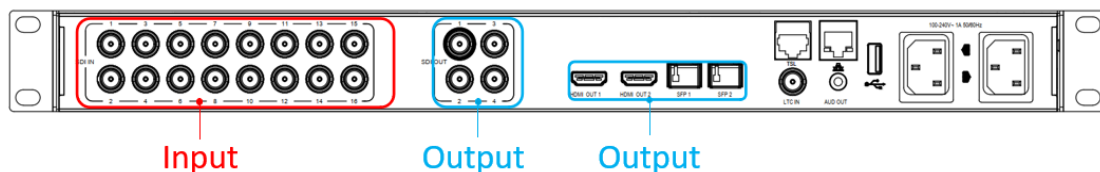

Figure 2.1.1 The Rear Panel of Argos1600

Tips

- The connectors for the input and the output are different, don't mixed when connect to the external devices.

2. Multi-image Processor and Control Computer

Connect the multi-image processor and its control computer with twisted-pair cable.

Tips

- The multi-image processor and its control computer must be at the same network segment.
- The default IP address of ARGOS multi-image processor is 192.168.1.2.

3. Software Operating Environment

- Supports these operating systems: Windows 7 sp1 or above
- Microsoft .NET Framework: Microsoft .NET Framework 4.6.1 or above
- Display screen resolution: 1024x768 or above

2.2 Startup Argos

Connect to the control computer, and navigate to the Argos.exe file under the folder where the multi-image processor software installed. Double click Argos program OSEE.ArgosV*.exe to start up Argos1600 system editor, and connect to a multi-image processor. It will pop up **User Login** dialog box, as shown in Figure 2.2.1:

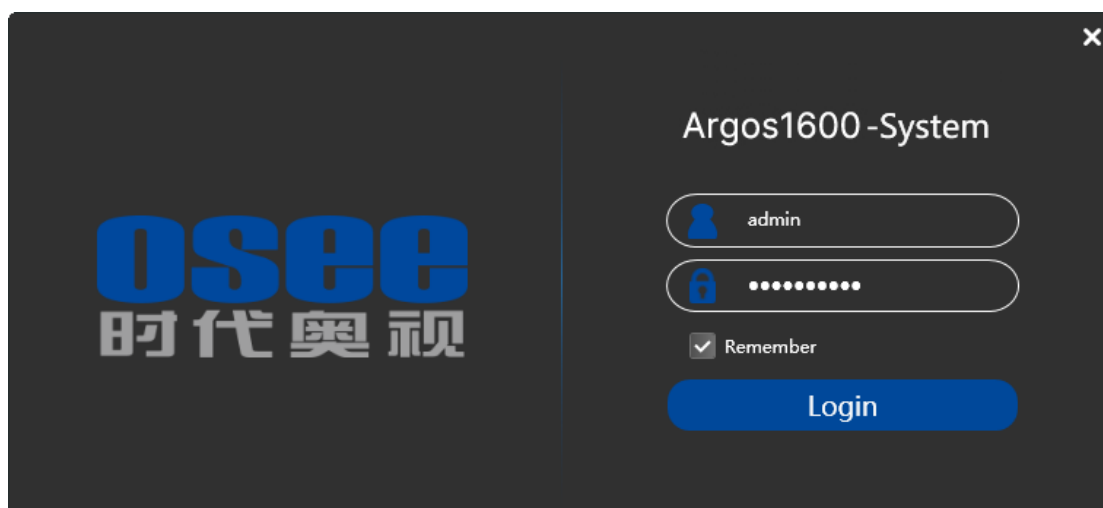

Figure 2.2.1 User Login Dialog Box

Enter user name and password, then click **Login** button to confirm the inputs.

i Tips

- The default account is “admin”, and the password is “osee123456”. The default “admin” account should not be deleted.
- Tick off the “Remember” selection, then you don’t need to enter the password next time.

After successful login, the interface of Argos Multi-image System Editor is as shown in Figure 2.2.2:

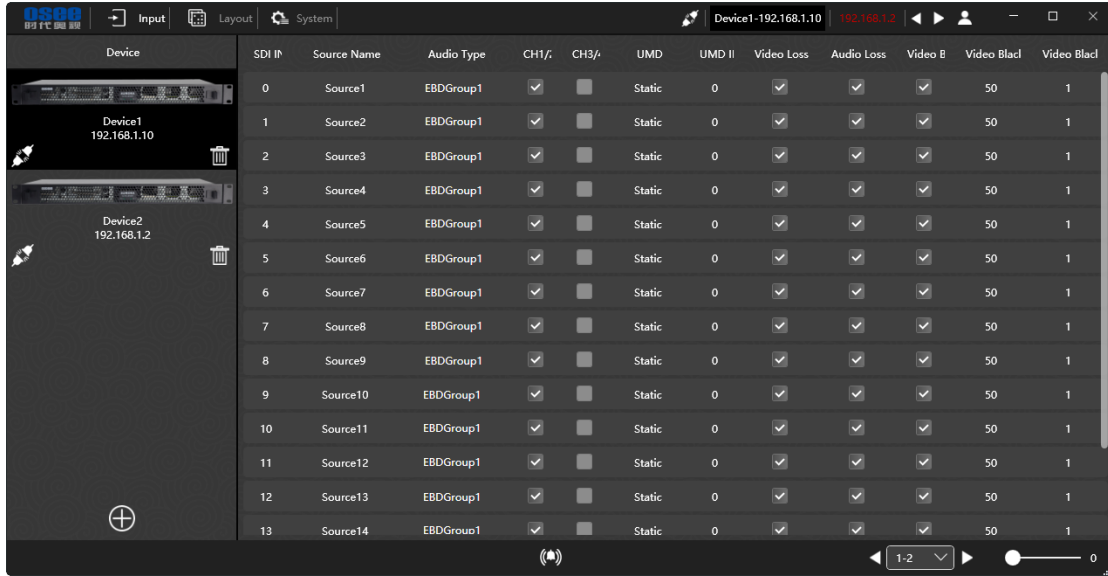

Figure 2.2.2 Interface of Argos Multi-image System Editor

Tips

- In case of unexpected errors to Argos, please turn off the firewall before starting up Argos.
- The argos multi-image system editor will read the information of the input and output connected with the control computer.

The interface of Argos multi-image system editor is divided into the following areas, as shown in **Figure 2.2.3**:

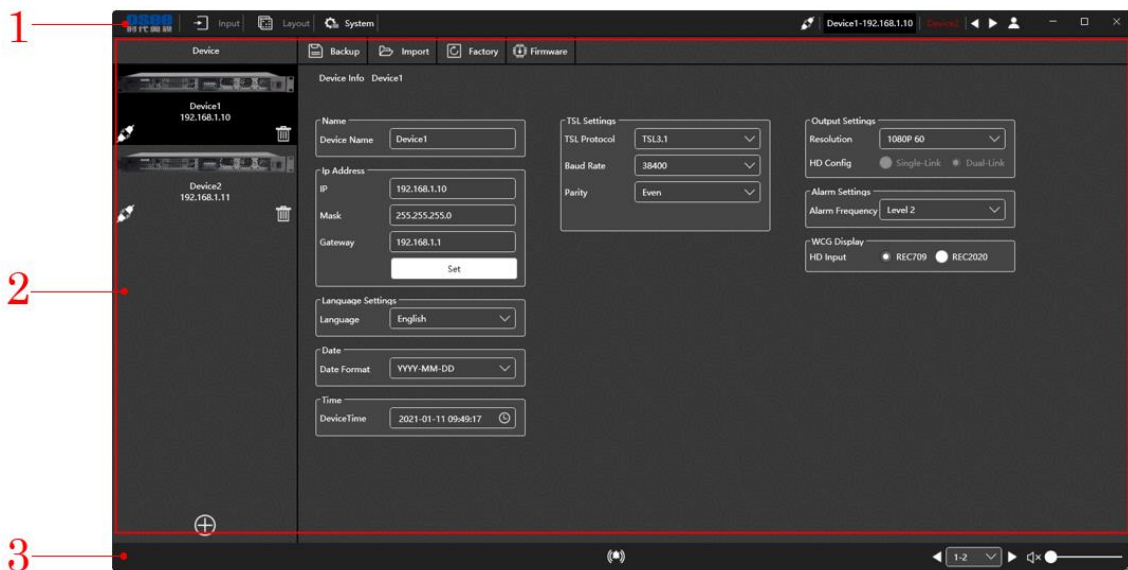











Figure 2.2.3 Operation Areas in Argos Multi-image System Editor

1. **Title Bar:** it contains the icon, the name of the software, switch buttons for configuration pages, connect button for device, help button and a group of system buttons from left to right.

- ❑ **Software LOGO:** the icon and the name of the software.
- ❑ **Configuration Buttons:** the configuration objects are INPUT, LAYOUT and SYSTEM, click the tab labeled the object name in the title bar to switch to the target configuration pages.
- ❑ **Device Switch and Connect Buttons:** connect or disconnect devices. Click connection button  to connect or disconnect the current device. Click a device tab to switch it as the current device.

Menu	Command	Shortcut Button	Description
Device Connect	Connect		Indicate the online status, and click the button to disconnect the active device.
	Disconnect		Indicate the offline status, and click the button to connect the active device.
Help	Modify password		It is used to modify the password of the current user.
	About		It is used to display the basic and version information about this software.
	Language		It is used to switch an interface language for this software, selecting from Chinese and English.

- ❑ **Windows Control Buttons:** these control buttons at the right end of the title bar are used to minimize/maximize window, restore window and close window.
2. **Working Area:** it is used to switch to the configuration pages to configure the system, input sources and layouts by clicking the corresponding tabs in the title bar.
- ❑ **SYSTEM:** it is used to configure argos devices, network, alarm, TSL settings, output mapping, etc.
 - ❑ **INPUT:** it is used to configure the signal source information, including signal source name, audio meter mapping, UMD source, video and audio alarm (video black alarm, video loss alarm, audio loss alarm).

- LAYOUT: it is used to configure the layout and template, including adding display elements (monitor window, analog clock timer, digital clock timer, countdown timer, and digital data timer), elements arrangement and properties assignment.
3. **Status bar:** it provides the alarm log, audio output channel selection buttons and volume adjustment button in this area.
- **Alarm Log:** click the alarm icon  in the status bar, it will pop up the alarm log list, refer to "3.3.4 Alarm Log" for the details.
 - **Audio output channel selection button:** click the right or left arrow beside the audio output channel selection button , or click this button to draw down a list to select an audio channel to output from: 1-1, 1-2, 2-1, 2-2, 3-1, 3-2, 4-1, 4-2, 5-1, 5-2, 6-1, 6-2, 7-1, 7-2, 8-1, 8-2, 9-1, 9-2, 10-1, 10-2, 11-1, 11-2, 12-1, 12-2, 13-1, 13-2, 14-1, 14-2, 15-1, 15-2, 16-1, 16-2.
 - **Volume Control:** set the volume by the volume control button or volume slider. Single click the volume control button  to mute the output audio, and the icon switches to , the volume is 0. Besides, drag the volume slider  to the leftmost position, volume is 0, too. Drag the slider to the left for volume down, and to the right for volume up, and the range is 0~100.

2.3 Software Interface

This section will introduce the contents and functionalities of the operation windows.

The Argos multi-image system editor provides several interfaces for different objects: **SYSTEM** Configuration, **INPUT** configuration, and **LAYOUT** configuration. Click the corresponding tab at the top in the title bar to switch to the related configuration window.

For example: click the tab name from **INPUT** to **LAYOUT** as below:

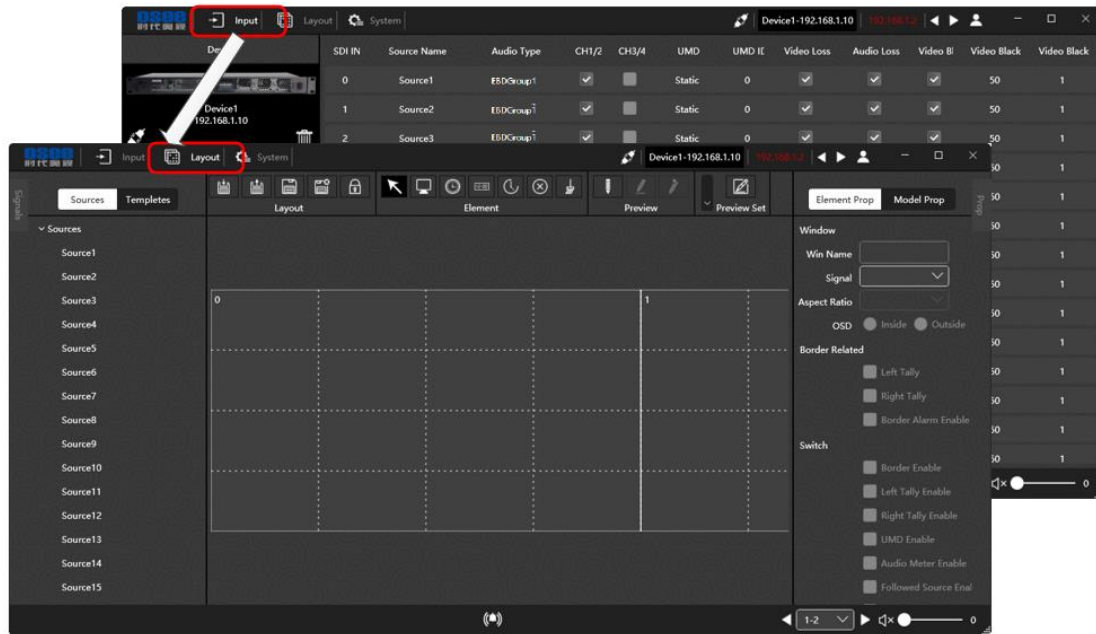
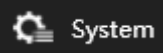

Figure 2.3.1 Configuration Window Switch

2.3.1 SYSTEM Configuration Window

SYSTEM tab  in the title bar, it will display the system configuration workplace, as shown in **Figure 2.3.2**. In the system configuration window, you can add argos Argos1600 multi-image processor, set up devices connection, configure device and so on.

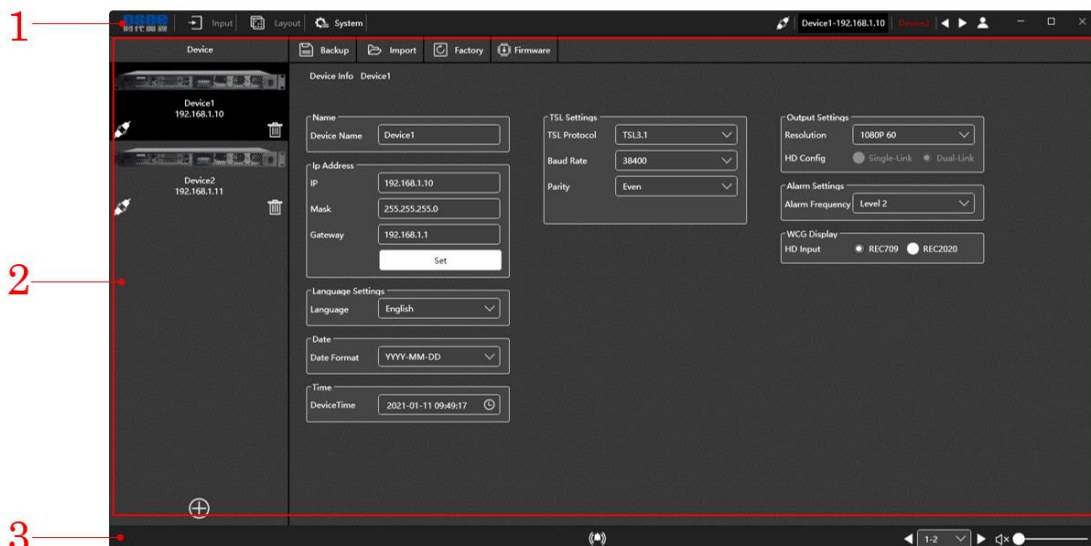









Figure 2.3.2 System Configuration Window

- **Switch Device:** You can switch among devices by clicking the device list in the left pane of system configuration window.
- The language setting is a global parameter available for all the devices in the list.

1. Commands

It lists the commands used for system configuration.

Type	Command	Shortcut icon	Description
Data	Backup		It is used to export the input, layout or system data to the destination folder.
	Import		It is used to import the data to the current device.
	Factory		It is used to restore the factory default to this current device.
	Firmware		It is used to upgrade the hardware of the current device.
Connect	Connect		Indicate online status, click this button to set up a connection to the device.
	Disconnect		Indicate offline status, click this button to cut down connection to the device.
System	Edit Password		It is used to modify the password of the current user.
	About		It is used to display the basic software information of Argos.
	Soft Language		It is used to switch an interface language for this software, selecting from Chinese and English.

Tips

- **System** is a global menu, it appears in the title bar of each configuration window.

2. Device list pane in system configuration window

It provides the system sources for device configuration.

It displays the device information at the left pane in system configuration window, including the name, IP address, connection status, add and delete buttons, as shown in Figure 2.3.3.



Figure 2.3.3 Device Tree

Single click a device to select the target device in this device list, and there will be its detail settings in the right working area.

3. Working area for configuring device information

The device information is listed in the working area of system configuration window, including the following items: Device Name, IP Address, TSL Settings, Output settings, WCG Display, etc.

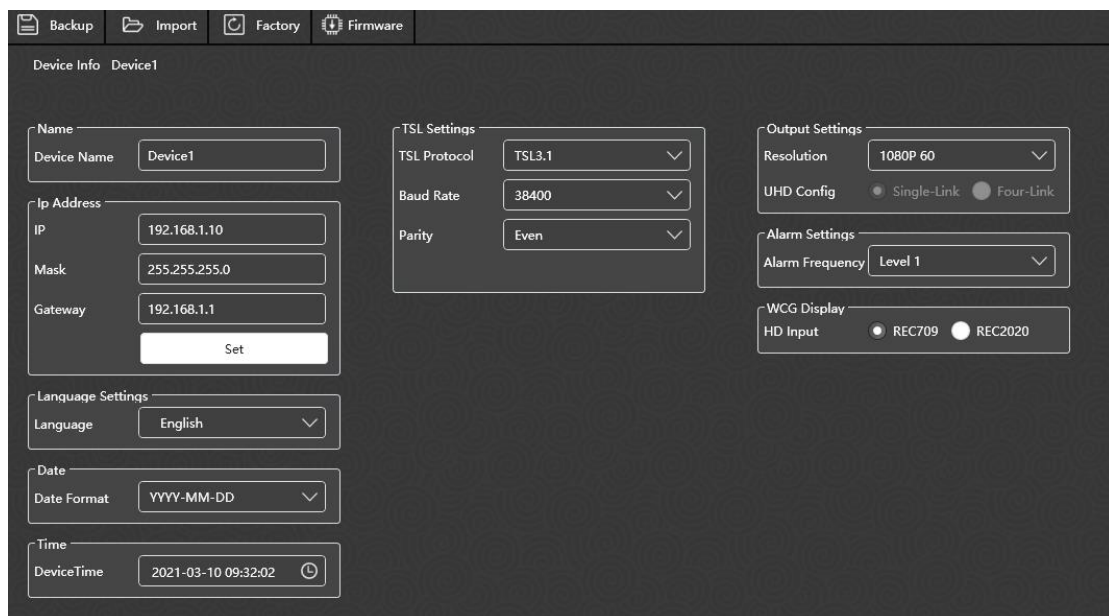

Figure 2.3.4 Working Area of Project Configuration

Refer to “3.2 System Configuration” for the details about system configuration.

2.3.2 Input Configuration Window

Click **INPUT** tab in the title bar, it will display the input configuration workplace, as shown in Figure 2.3.5, it is used to modify the signal source name, create the mapping relationship between the audio channel and audio meter, configure UMD, video and audio alarms.

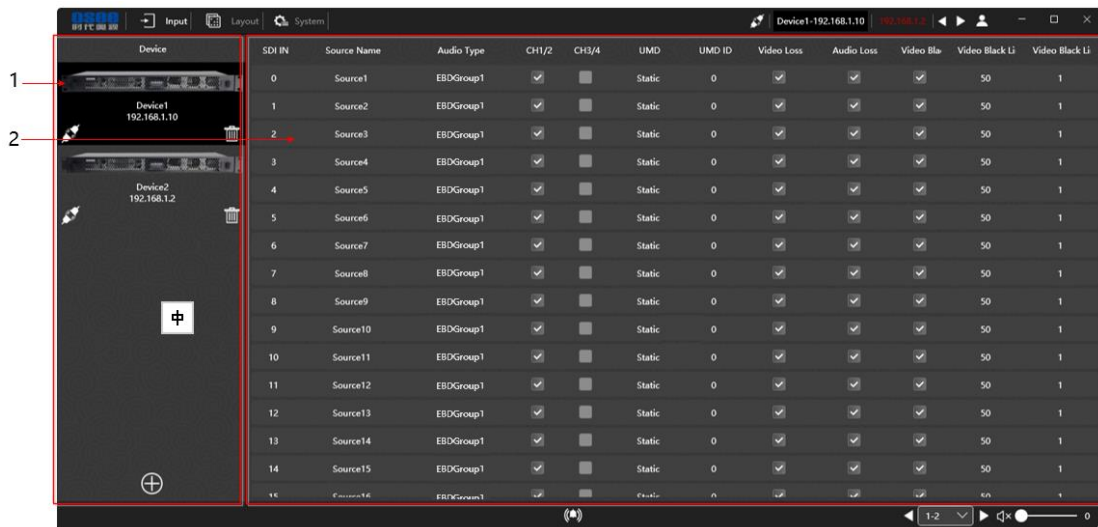

Figure 2.3.5 Input Configuration Window

1. Device pane in input configuration window

It provides the device list as the same as in the system window, no further details in this part.

2. Working area for input list

The inputs information for the current device is listed in a table.

The Input List includes: **SDI IN, Source Name, Audio Type, CH1/2, CH3/4, UMD Type, UMD ID, Video Loss Alarm, Audio Loss Alarm, Video Black Alarm, Video Black Limit1, and Video Black Limit2**, as shown in

SDI IN	Source Name	Audio Type	CH1/2	CH3/4	UMD	UMD ID	Video Loss	Audio Loss	Video Bla	Video Black Li	Video Black Li
0	Source1	EBDGroup1	<input checked="" type="checkbox"/>	<input type="checkbox"/>	Static	0	<input checked="" type="checkbox"/>	<input checked="" type="checkbox"/>	<input checked="" type="checkbox"/>	50	1
1	Source2	EBDGroup1	<input checked="" type="checkbox"/>	<input type="checkbox"/>	Static	0	<input checked="" type="checkbox"/>	<input checked="" type="checkbox"/>	<input checked="" type="checkbox"/>	50	1
2	Source3	EBDGroup1	<input checked="" type="checkbox"/>	<input type="checkbox"/>	Static	0	<input checked="" type="checkbox"/>	<input checked="" type="checkbox"/>	<input checked="" type="checkbox"/>	50	1
3	Source4	EBDGroup1	<input checked="" type="checkbox"/>	<input type="checkbox"/>	Static	0	<input checked="" type="checkbox"/>	<input checked="" type="checkbox"/>	<input checked="" type="checkbox"/>	50	1
4	Source5	EBDGroup1	<input checked="" type="checkbox"/>	<input type="checkbox"/>	Static	0	<input checked="" type="checkbox"/>	<input checked="" type="checkbox"/>	<input checked="" type="checkbox"/>	50	1
5	Source6	EBDGroup1	<input checked="" type="checkbox"/>	<input type="checkbox"/>	Static	0	<input checked="" type="checkbox"/>	<input checked="" type="checkbox"/>	<input checked="" type="checkbox"/>	50	1

Figure 2.3.6:

SDI IN	Source Name	Audio Type	CH1/2	CH3/4	UMD	UMD ID	Video Loss	Audio Loss	Video Bla	Video Black Li	Video Black Li
0	Source1	EBDGroup1	<input checked="" type="checkbox"/>	<input type="checkbox"/>	Static	0	<input checked="" type="checkbox"/>	<input checked="" type="checkbox"/>	<input checked="" type="checkbox"/>	50	1
1	Source2	EBDGroup1	<input checked="" type="checkbox"/>	<input type="checkbox"/>	Static	0	<input checked="" type="checkbox"/>	<input checked="" type="checkbox"/>	<input checked="" type="checkbox"/>	50	1
2	Source3	EBDGroup1	<input checked="" type="checkbox"/>	<input type="checkbox"/>	Static	0	<input checked="" type="checkbox"/>	<input checked="" type="checkbox"/>	<input checked="" type="checkbox"/>	50	1
3	Source4	EBDGroup1	<input checked="" type="checkbox"/>	<input type="checkbox"/>	Static	0	<input checked="" type="checkbox"/>	<input checked="" type="checkbox"/>	<input checked="" type="checkbox"/>	50	1
4	Source5	EBDGroup1	<input checked="" type="checkbox"/>	<input type="checkbox"/>	Static	0	<input checked="" type="checkbox"/>	<input checked="" type="checkbox"/>	<input checked="" type="checkbox"/>	50	1
5	Source6	EBDGroup1	<input checked="" type="checkbox"/>	<input type="checkbox"/>	Static	0	<input checked="" type="checkbox"/>	<input checked="" type="checkbox"/>	<input checked="" type="checkbox"/>	50	1

Figure 2.3.6 Inputs List

■ SDI IN

There are 16 input channels in total, and the ID for each SDI input channel is setting from 0 to 15.

Tips

- The range of input ID number is from 0 to 15, corresponding to the NO.1 to No.16 SDI INPUT connector.

■ Source Name

The default name of input consists of the "Source" character and channel number item, such as "**Source1**", thus to indicate the SDI input connector sequence apparently.

Double click the source name field to customize it as you wish.

Tips

- Particularly, the characters of source name will be used to structure the static UMD characters.

Refer to for "3.3 Input Configuration" the details.

2.3.3 Layout Configuration Window

Click **LAYOUT** tab  **Layout** in the title bar, it will display the layout configuration workplace, as shown in **Figure 2.3.7**, it is used to configure the template.

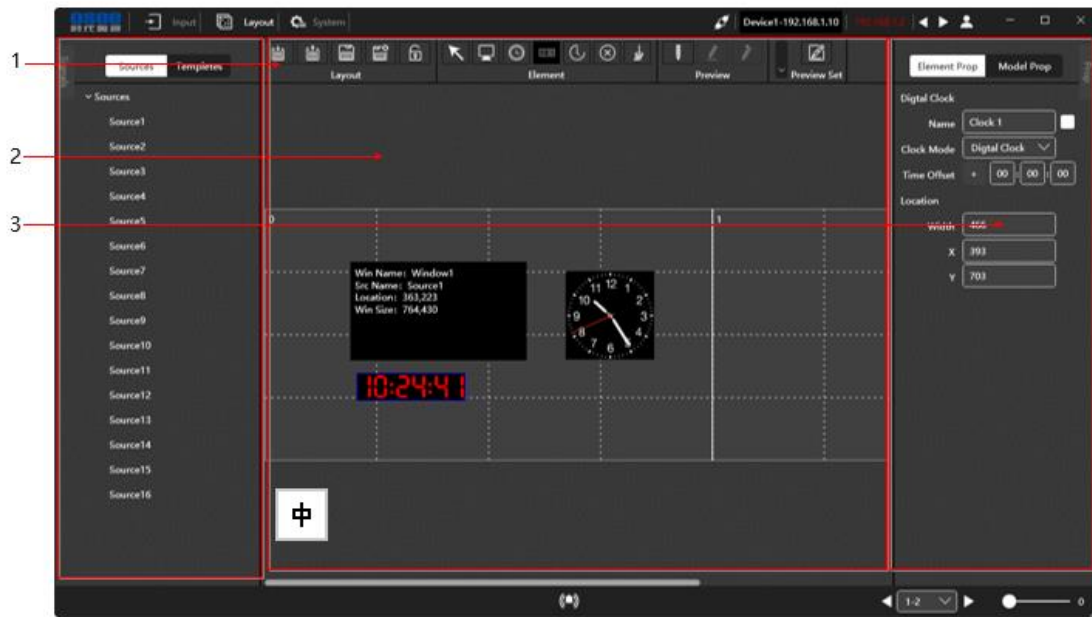

Figure 2.3.7 Layout Configuration Window

Configure the template in the layout configuration window, the details are as follows:

1. System pane for template configuration

It provides the Sources and Templates list for layout configuration, as shown in Figure 2.3.8:



Figure 2.3.8 System Pane for Layout Configuration

- **Sources:** It provides the signal sources available for the monitor elements. Click and drag a signal source from the sources list in system pane to a target monitor element in working area, thus to establish the mapping relationship, as shown in Figure 2.3.9:

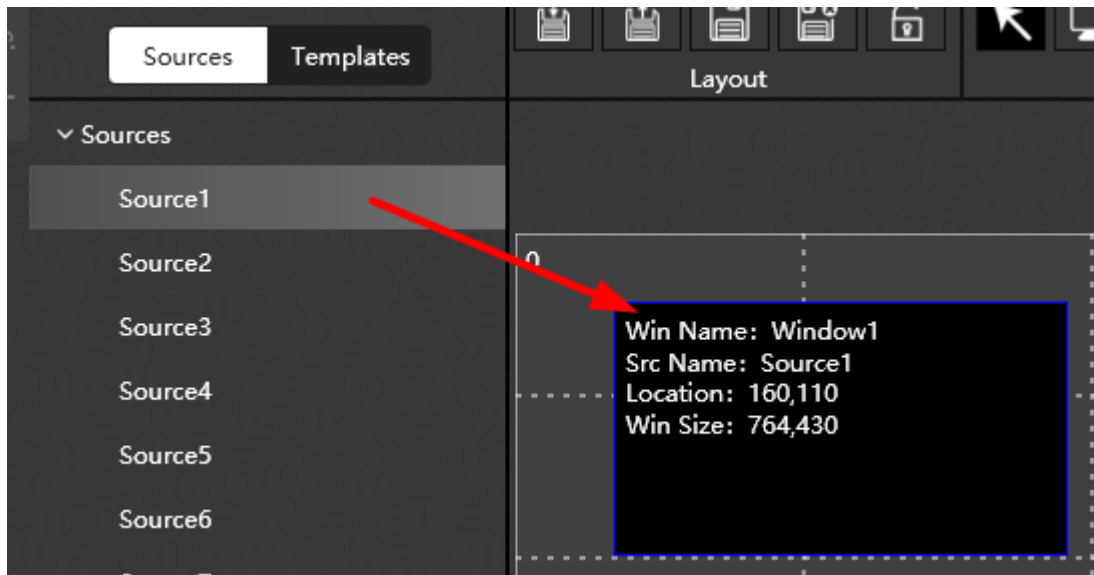

Figure 2.3.9 Signal Source for a Monitor Element

- **Templates:** It provide various templates in the Templates pane, including preset templates and customized templates, as shown in Figure 2.3.10:

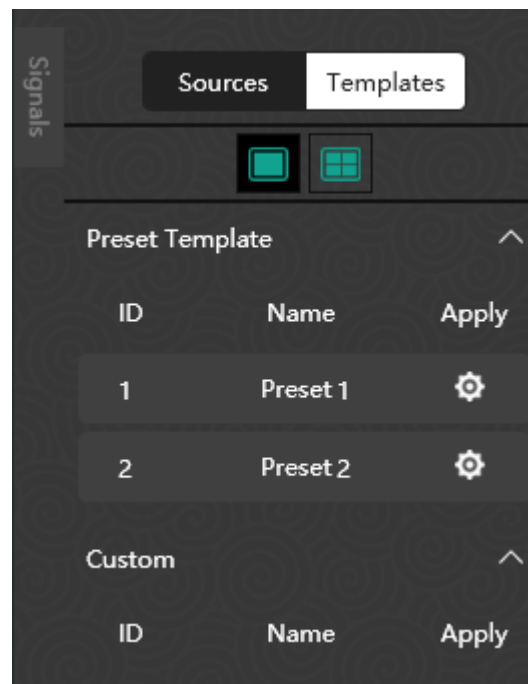

Figure 2.3.10 Templates for a Layout

2. Working area for template configuration

It provides a workplace for adding, arranging and editing all element windows for a layout.

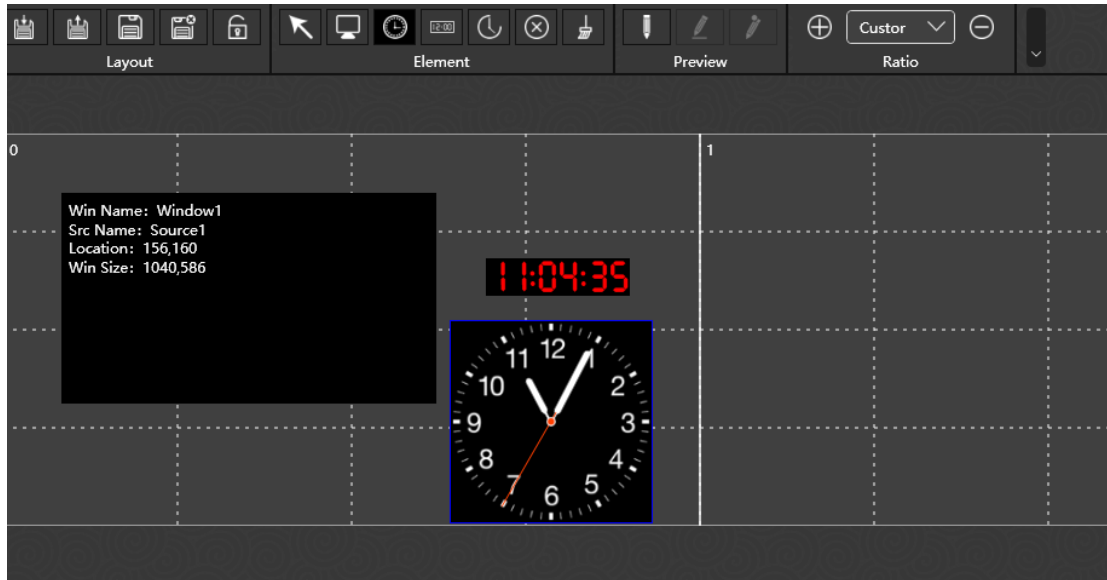

Figure 2.3.11 Working Area for Template Configuration

When you are creating templates, Argos offers a serial of tools for configuring the template.

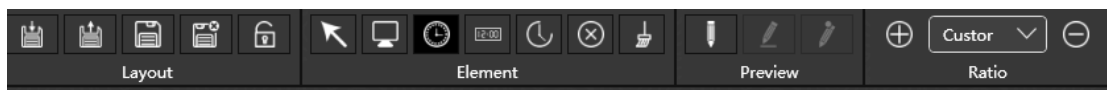











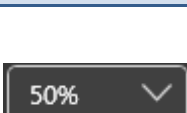

Figure 2.3.12 Arrange Tools for Template Configuration

- Arrange tools:** it provides various commands used for template configuration.

Menu	Command	Shortcut Button	Description
Layout	Import		It is used to restore template data to the selected template.
	Export		It is used to save the selected templates to a specified directory.
	Save		It is used to save the configuration changes to the current edited template.
	Delete		It is used to delete the current template window in working area.
	Lock		Lock or unlock the current template. The other commands in the tool bar are only available in unlock mode.
Element	Select		It is used to select an element window.

Menu	Command	Shortcut Button	Description
	Window		It is used to add a monitor element.
	Analog Clock		It is used to add an analog clock element.
	Digital Clock		It is used to add a digital clock element.
	countdown Clock		It is used to add a countdown clock or a date element.
	Delete Element		It is used to delete the current selected element in working area.
	Clear Element		It is used to delete all the elements in current template in working area.
Preview	Enter		It is used to enter into the preview mode, you can edit the current layout in working area without sending the changes to the physical display device.
	Apply		It is used to apply the changes to the physical display device in online status.
	Exit		It is used to exit the preview mode.
Ratio	Zoom In		It is used to zoom in the display area of the monitor in working area. Click once to zoom in 10%.
	Zoom Out		It is used to zoom out the display area of the monitor in working area. Click once to zoom out 10%.
	Ratio		It is used to control the display ration of the layout, providing these ratios: 50%, 75%, 100%, 120%, 150%, 170%, 200%, 250%, 300%. Best is used to zoom the display area of the layout to fitting with configuration window.

Tips

- Scroll the mouse wheel up or down when the mouse cursor in the working area of monitor configuration, it will zoom in or zoom out the display area convenient for checking.

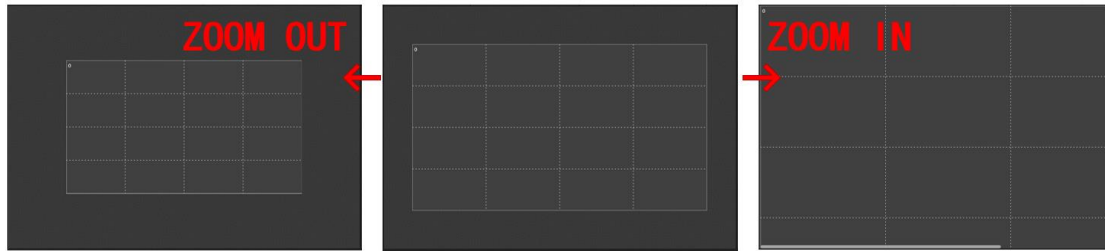

Figure 2.3.13 Zoom In and Zoom Out the Working Area for Monitor Configuration

3. Property pane for template configuration

It provides the property list for model properties and element properties. Modify the value for a property, click **Enter** key to confirm modification, and click save command to save the changes.

- ❑ **Model Properties:** Show the properties list for the current template.
- ❑ **Element Properties:** Show the properties list for the selected element, as shown in Figure 2.3.14:

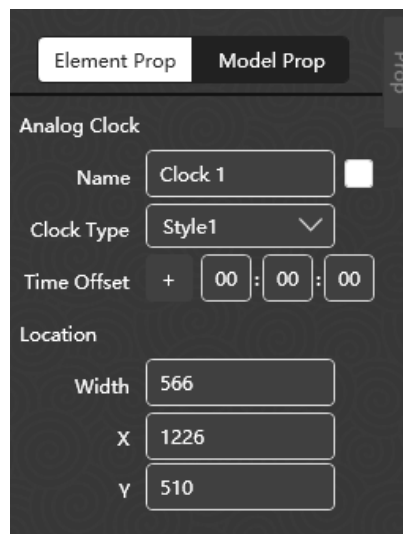

Figure 2.3.14 Properties Pane for Layout Configuration

i Tips

- The parameters list in elements properties pane are different according the type of the selected element in working area.

Chapter 3 Functionalities and Operations

This chapter is used to introduce the functionalities and operations in Argos multi-image system editor.

3.1 Basic Function

3.1.1 Login and User Management

Double click Argos program to start up Argos1600 system editor, and connect to a multi-image processor. It will pop up **User Login** dialog box.

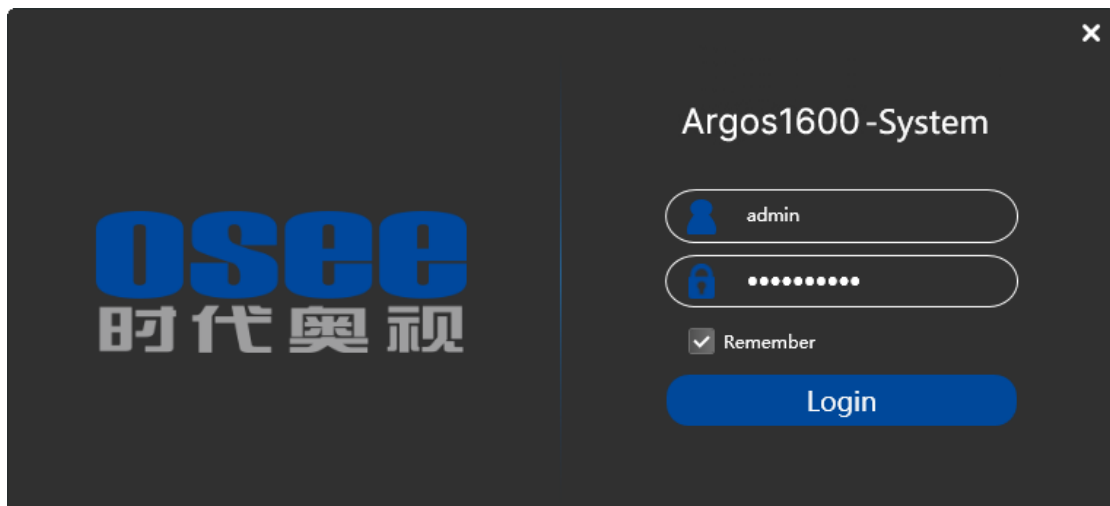



Figure 3.1.1 Login Dialog Box

Enter the user name and password, then click **Login** button to confirm the inputs.

Tips

- The default account is “admin”, and the password is “osee123456”. The default “admin” account should not be deleted.
- Tick off the “Remember” selection, then you don’t need to enter the password next time.

You could modify the password to be a new one after you login successfully.

Click the User button  at the right side of the title bar to activate the corresponding user command, as shown in Figure 3.1.2, it will display the drop-down list of user commands, select **Edit Password** command on the User button.

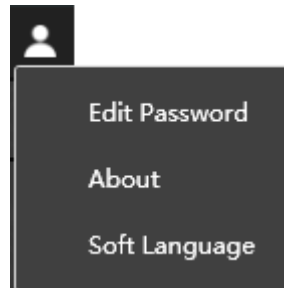

Figure 3.1.2 User Commands

It will pop up the **Edit Password** window, as shown in Figure 3.1.3:

A dark grey dialog box titled 'Edit Password' with a close button (X) in the top right corner. It contains three text input fields: 'Old Password', 'New Password', and 'Sure Password'. At the bottom, there are two buttons: 'OK' and 'Close'.

Figure 3.1.3 Edit Password

At first, enter the old password in the field of **Old Password**, then enter the new password in the field of **New Password**, and repeat the new one in field of **Sure Password**, then click **OK** button to confirm the modification, it will pop up a successful prompt , as shown in Figure 3.1.4. Click **OK** to complete the modification of password.

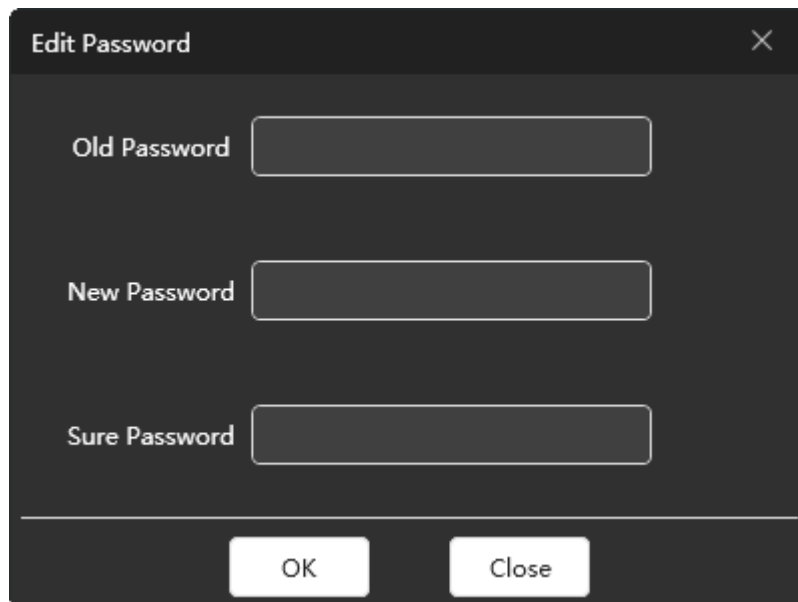
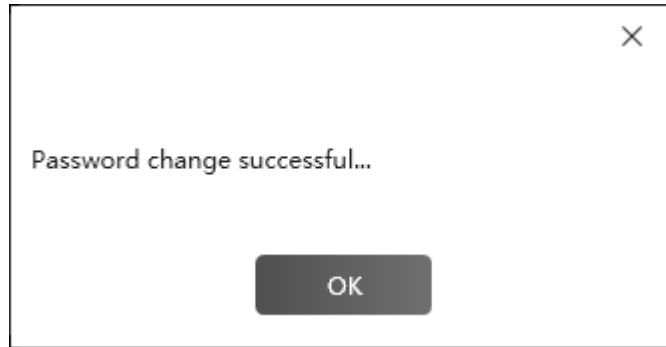

Figure 3.1.4 Update Password Successfully

3.1.2 Add Device

You can add a new device by the following two methods:

1. Add Device Method

Add a device in the device list of System page or Input page.

Tips

- You can add a new device by New Device command, or by Search Devices command.
-

■ Add device--New Device

Click **Add** button  at the bottom of the device list, it will pop up the add device dialog box, as shown in Figure 3.1.5:

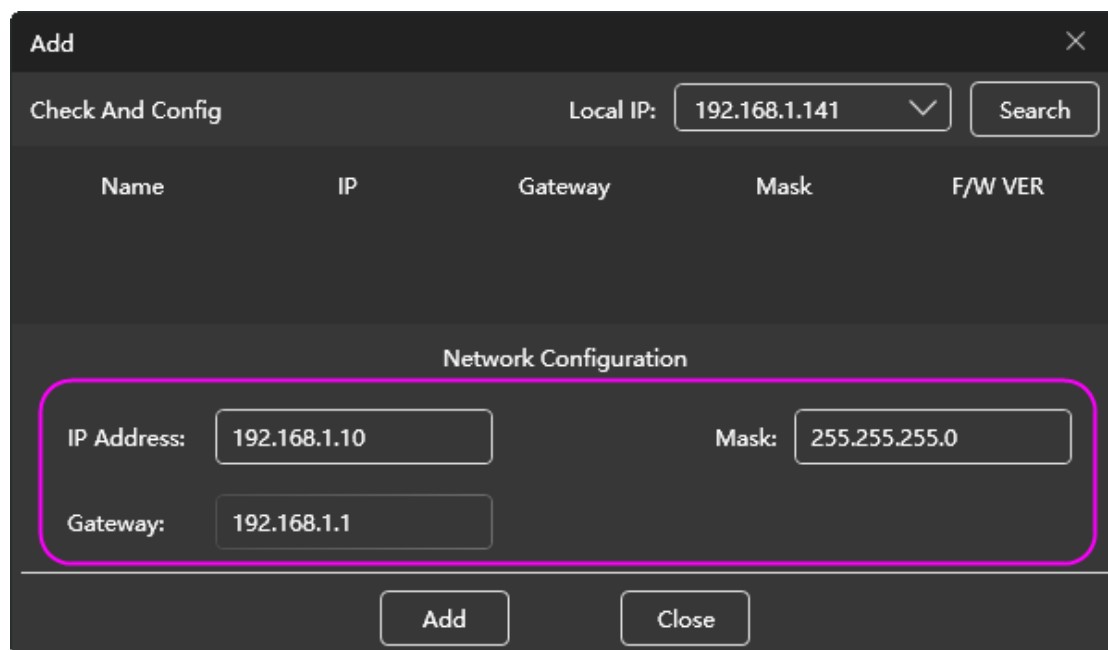

Figure 3.1.5 Add Device

Type a new IP Address, Mask and Gateway in the field of Network Configuration field, then click **Add** button, the new device will be add into the device list, as shown in Figure 3.1.6.



Figure 3.1.6 New Device in Device List

Tips

- Click the target device in device list, and you can modify the device information in system.

■ Add device--Search Device

Click **Search** button to find out the available devices information in the current network.

It lists the following information: **Name, IP, Gateway, Mask** and **Firmware Version**.

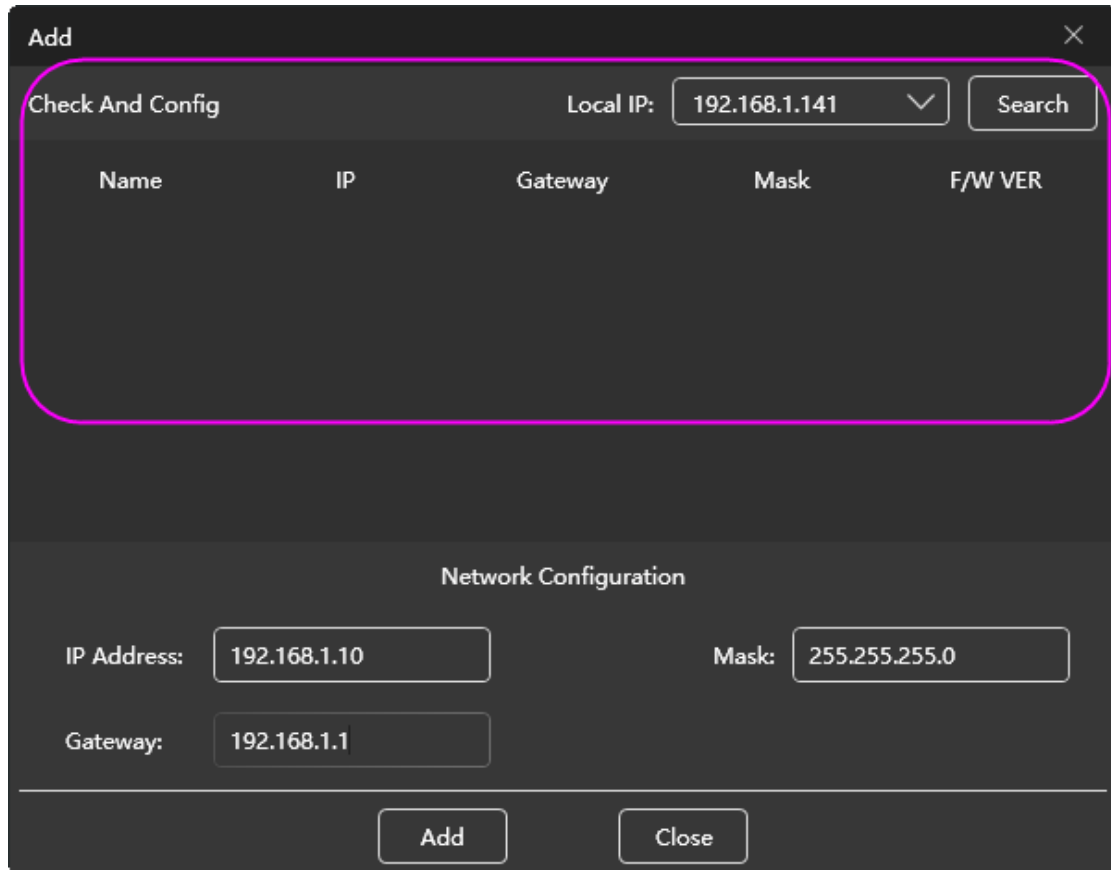

Figure 3.1.7 Search Device List

Select a device in the search list box, as shown in Figure 3.1.8, then click **Add** button, the new will be add into the device list.

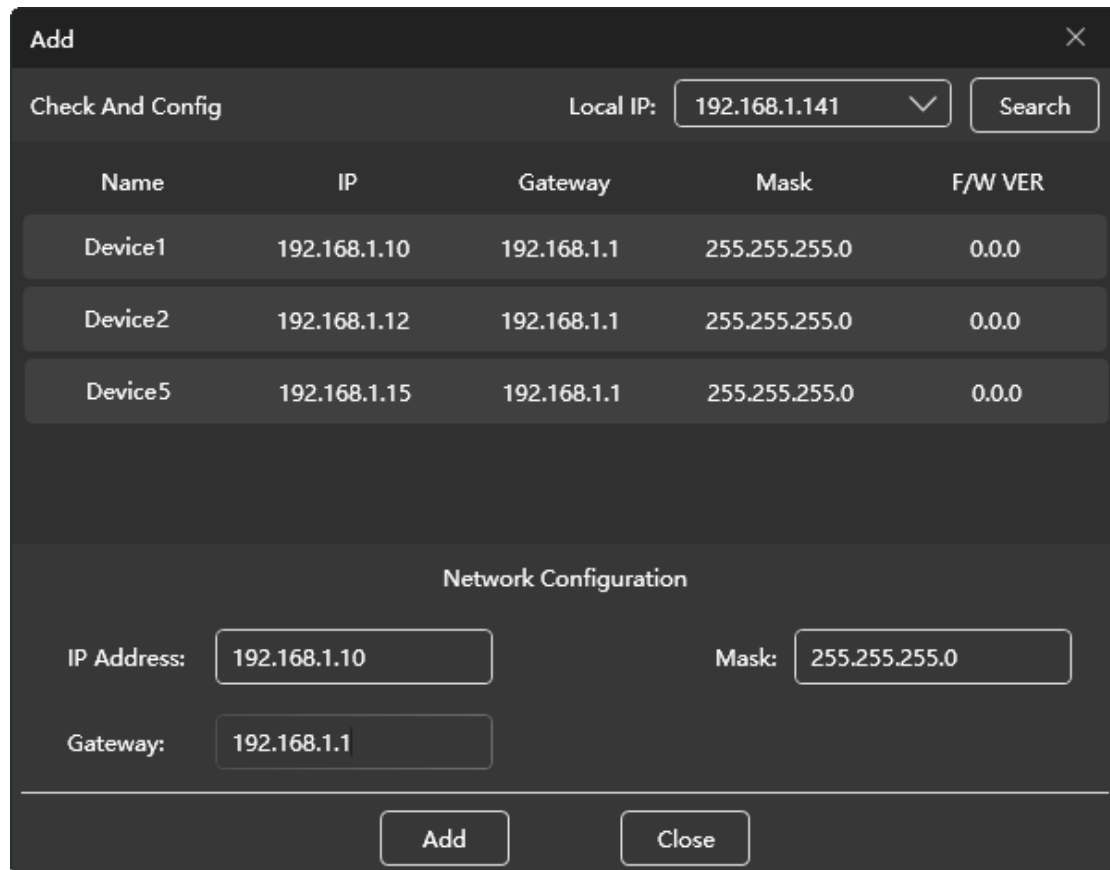

Figure 3.1.8 Search Result

2. Modify the device settings

Select the target device in the device list of system page, it will list its information in the right area, as shown in Figure 3.1.9, you can modify these network settings, then click **Set** button to complete the modification.

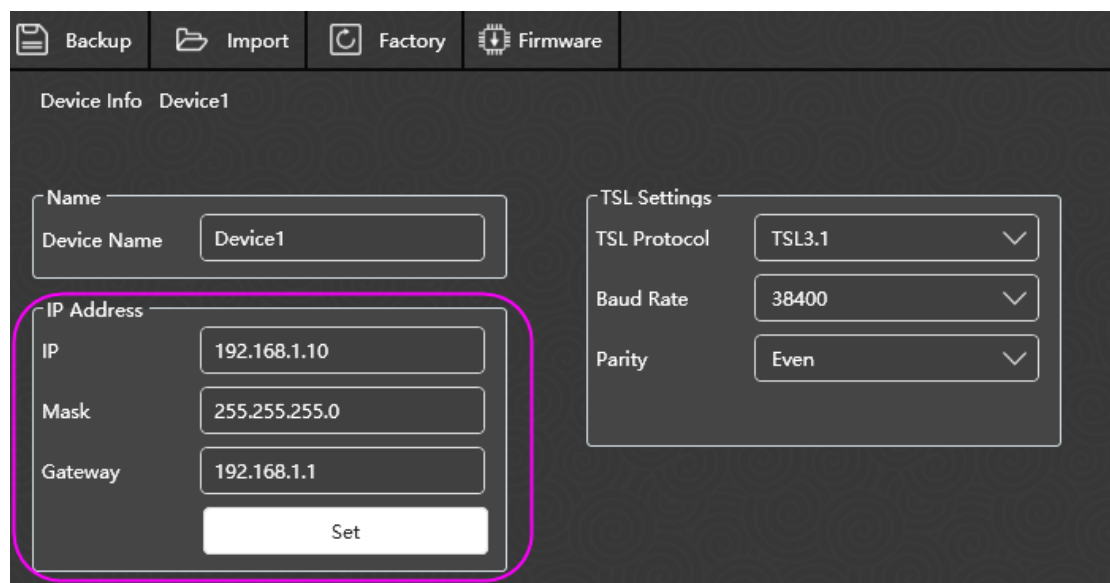

Figure 3.1.9 Device Info

Warning

- In online mode, change IP address in **Device Info** → **IP Address** → **IP** field, then click **Set** button to confirm the modification, it will pop up a prompt, as shown in Figure 3.1.10, After that, make sure to restart the argos device to take the new IP effect.

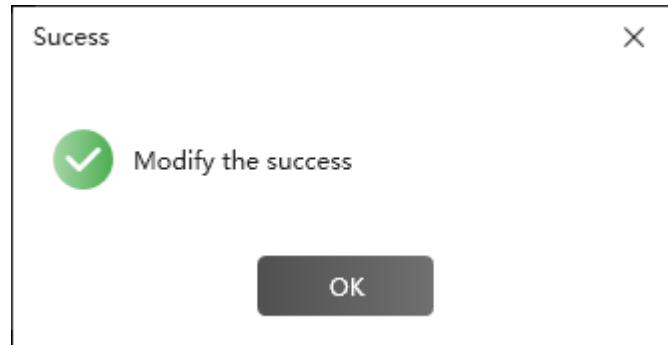

Figure 3.1.10 Prompt for Modifying Password

3.1.3 Device Connection

Connect or disconnect a device in the title bar of the Argos software interface. Click the device list to choose a device, then you can execute the connection or disconnection operations to the selected device. The current selected device name in the title is highlighted white, and the others are in red.



1. Device Status

In the system configuration window, you can check the device information.



Figure 3.1.11 Device List

You can check the device name, device type, IP address and connection status in **device list**. There are three statuses as below:

- **ONLINE**: When detecting and setting up the connection between the target device and the control computer, the device name and IP address will be highlighted white in the title bar, and the connection status icon is ;
- **OFFLINE**: When not detecting the connection, it will show the Offline status .
- **Abnormal**: When detecting an abnormal connection to the device, the status is .

The status of device could also be read from the title bar and status.



Figure 3.1.12 Connection Status in Title Bar

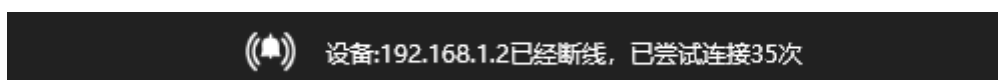



Figure 3.1.13 Connection Status in Status Bar



2. Connect and Disconnect

■ Connect device

Click Connect button  in title bar to connect the selected device, and

the icon will change into  for successful connection.

■ Disconnect device

Click the button  in title bar to cut off the connection with the selected device, and the icon will change into  for successful cutting down the connection.

3.2 System Configuration

At first, create a project for the argos system.

3.2.1 Add Device

Click **Add** button  at the bottom of the device list, it will pop up the add device dialog box, as shown in Figure 3.2.1:

Figure 3.2.1 Add Device

Type a new IP Address, Mask and Gateway in the field of Network Configuration field, or click **Search** button to add a device from the search result list, then click **Add** button. Refer to "3.1.2 Add Device" for the details.

Tips

- In Device Info area, change IP address in **Device Info**→ **IP Address**→**IP** field, then click **Set** button to confirm the modification.

For example: add two Argos1600 as shown in **Figure 3.2.2**.

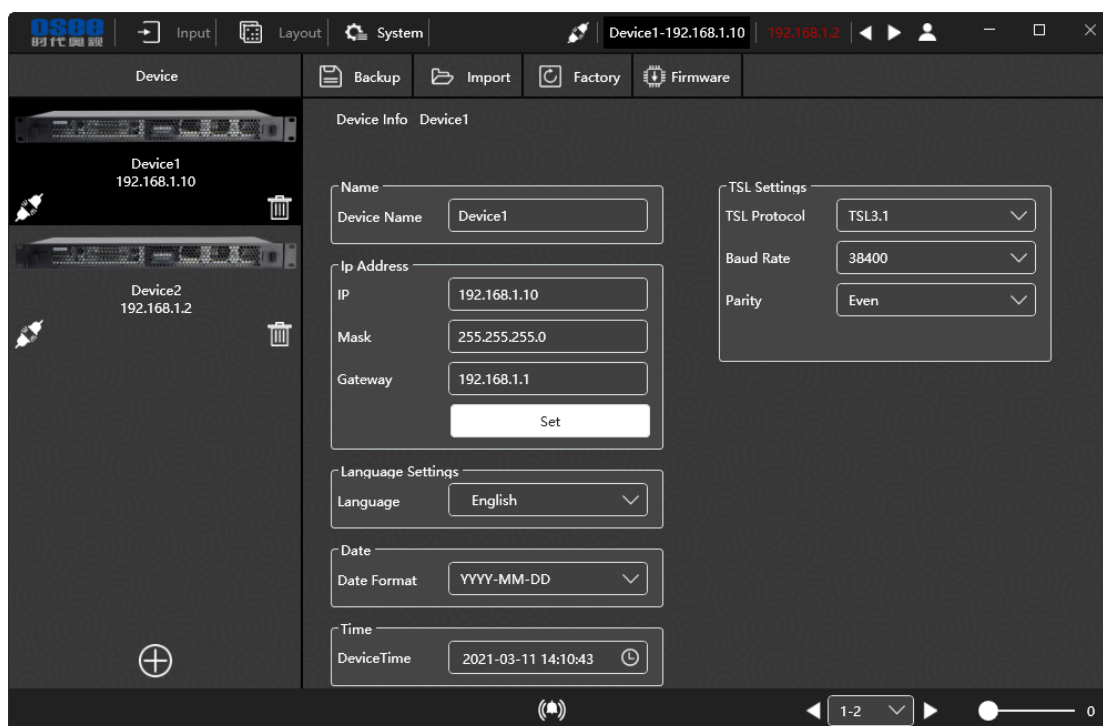

Figure 3.2.2 Device List in SYSTEM Page

3.2.2 Device Settings

In the right area of system configuration page, it displays the system settings of the current device selected in the device list, including **Device Name**, Network Settings, **Language**, **Time**, **Date**, TSL, Output settings, Alarm Settings and **WCG Display**, as shown in Figure 3.2.3:

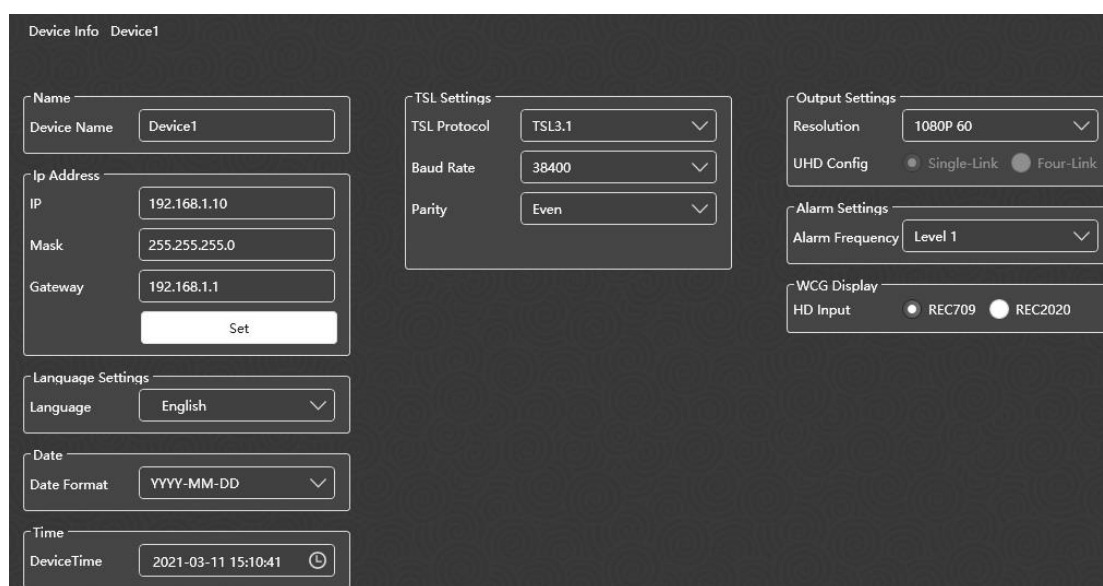

Figure 3.2.3 Device Information

Type	Item	Value Range	Default	Description
Name	Device Name	----	Device*	Set the device name for the multi-image processor
IP Address	IP	----	192.168.1.10	Set the IP address for the multi-image device
	Mask	----	255.255.255.0	Set subnet mask
	Gateway	----	192.168.1.1	Set gateway
Language Settings	Language	English/Chinese	Chinese	Set the language type of software interface
Date	Date Format	YYYY-MM-DD MM-DD-YYYY DD-MM-YYYY	YYYY-MM-DD	Set date
Time	Device Time	DD-MM-YYYY HHMMSS	Current system time	Set device time
TSL	TSL Protocol	TSL3.1: through TSL connector TSL4.0: through TSL connector TSL5.0: through Ethernet connector	TSL3.1	Set TSL Protocol
	Baud Rate	2400/4800/9600/ 19200/38400/ 57600/115200	38400	Set baud rate
	Parity	None/Odd/Even	Even	Set parity
Output Settings	Resolution	HD:1080i50, 1080i60, 1080P50, 1080P60 UHD:2160P25, 2160P30, 2160P50, 2160P60	--	Set output resolution
	UHD Config	Single-Link / Four-Link	Single-Link	Set the output format of UHD. Set as 2160P25, 2160P30, 2160P50, 2160P60 to HDMI1 or SDI1 output connector in single-link mode; set as 2160P50, 2160P60 to SDI1~4 output connector in four-link mode.
Alarm Settings	Alarm Frequency	Level1: 0.5s Level2: 1.0s Level3: 1.5s Level4: 2.0s	1.0s	Set the alarm blink frequency
WCG Display	HD Input	REC709/REC2020	REC709	Set the color space

Tips

- The device name can be composed of any characters, and the length of the name should not exceed 48 characters.
- Restart the multi-image processor to reconnect it with the control computer after you have modified its IP address.
- Only four numbers available for password.

1. Time Setting

Timing Setting is used to timing the multi-image processor manually. Click Time button to display the timing window, as shown in Figure 3.2.4:

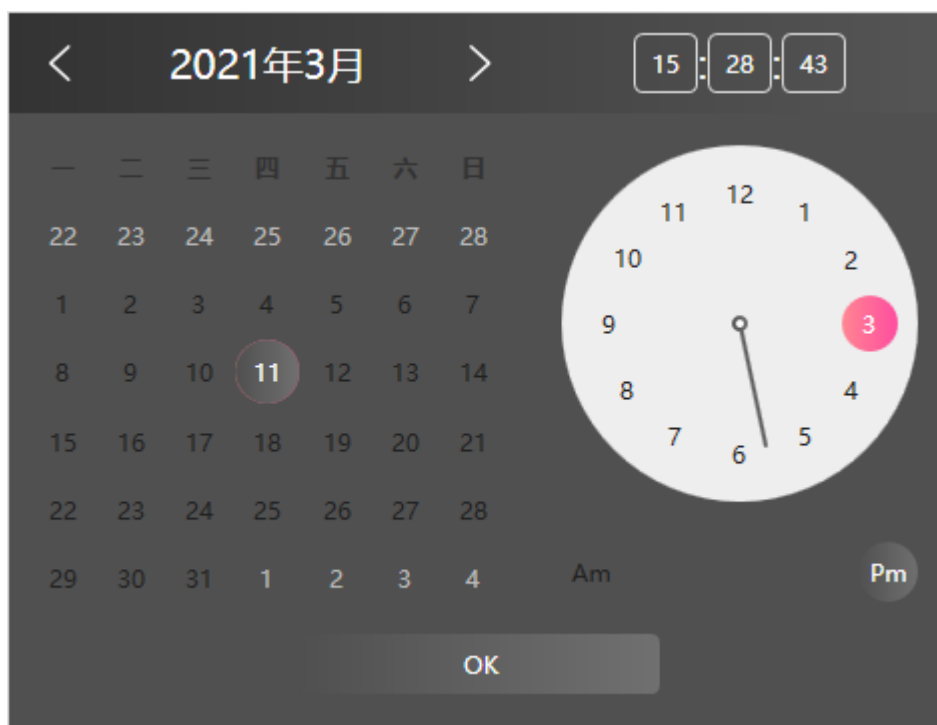

Figure 3.2.4 Timing Dialog Box

There are three timing methods:

- Synchronize System Time: to time with the system time coming from the control computer. The device time will synchronize with the computer time connected with multi-image processor;
- Custom Timing: time with a customized time set at the left time table in the timing dialog box as above;
- LTC Timing: time with the LTC time coming from the LTC IN connector provided by the third part LTC device.

Click **OK** button to confirm the timing operation, the timing successful prompt is as shown in Figure 3.2.5 , and the timing failed prompt is as shown in Figure 3.2.6:

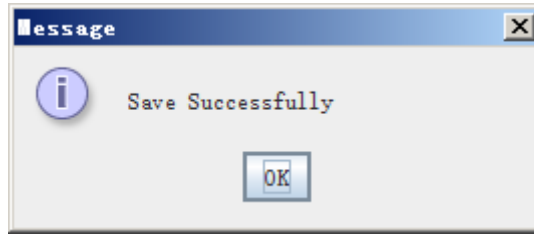

Figure 3.2.5 Prompt for Timing Successfully

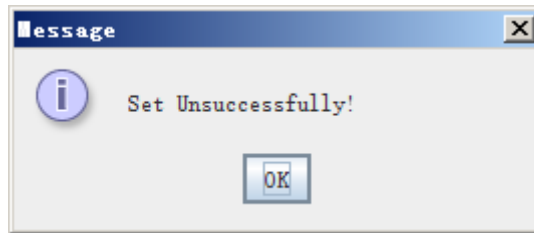

Figure 3.2.6 Prompt for Timing Failure

2. TSL Settings

Set the TSL parameters in the TSL Setting frame, including **TSL Protocol**, **Baud Rate** and **Parity**, as shown in Figure 3.2.7:

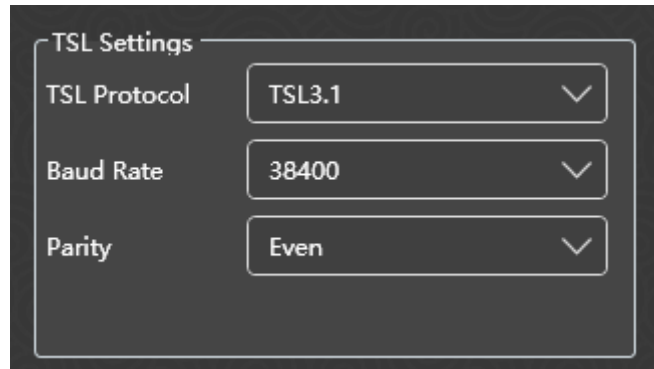

Figure 3.2.7 TSL Settings

i Tips

- It provides three kinds of TSL protocols by Argos1600: TSL3.1 and TSL4.0 through TSL connector, and TSL5.0 through Ethernet connector.

3. Output Settings

Select the output format through the Output Settings frame, as shown in Figure 3.2.8:

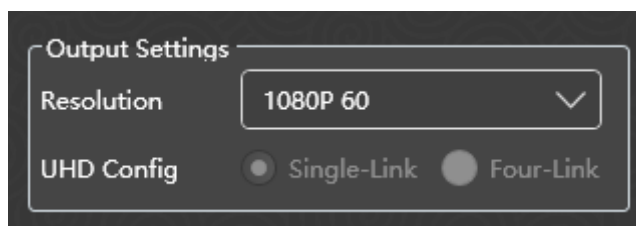

Figure 3.2.8 Output Format

- Resolution

Click the resolution item, it will show the drop list for output format in property pane: 1080i50, 1080i60, 1080P50, 1080P60, 2160P25, 2160P30, 2160P50, 2160P60.

- UHD Config

Set output mode. HD SDI uses Dual-Link as default.

- UHD Config: Single-Link or Four-Link, and the Four-Link only supports 2SI mode.

- The relationship between output format and output connector are as shown in the table below:

Output format	Single-Link	Dual-Link	Four-Link
1080i50	--	SDI1/SDI2 HDMI1/HDMI2	
1080i60	--	SDI1/SDI2 HDMI1/HDMI2	
1080P50	--	SDI1/SDI2 HDMI1/HDMI2	
1080P60	--	SDI1/SDI2 HDMI1/HDMI2	
2160P25	SDI1 HDMI1		--
2160P30	SDI1 HDMI1		--

Output format	Single-Link	Dual-Link	Four-Link
2160P50	SDI1 HDMI1		SDI1~SDI4 SFP1~SFP4
2160P60	SDI1 HDMI1		SDI1~SDI4 SFP1~SFP4

3.2.3 Save Device

After adding the device, click **Backup** button  **Backup** in system page. Click the **Select** button in device backup dialog box to choose the directory and file name of the backup file, and check the data type from **Input**, **Layout** and **System** checkbox, then click **OK** to confirm the device save.

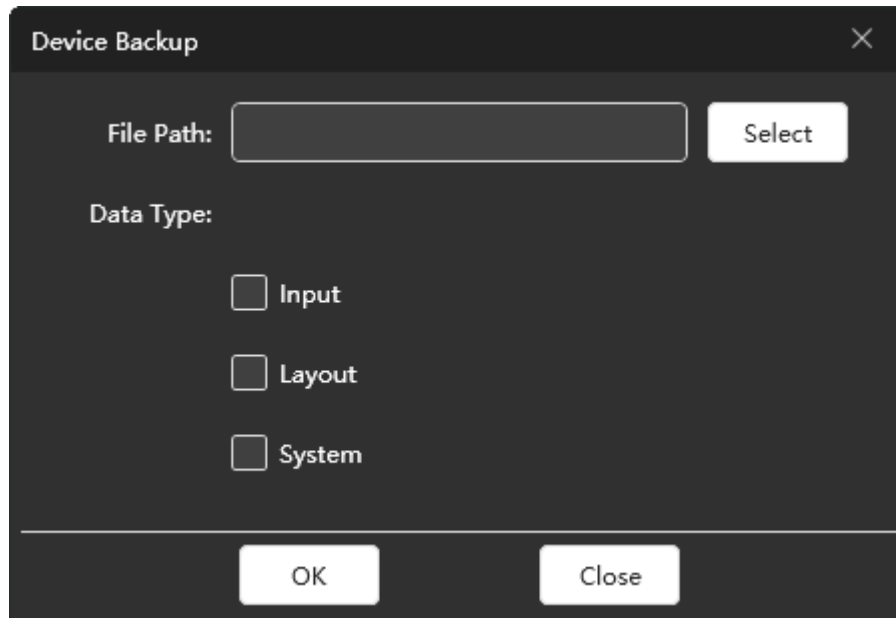

Figure 3.2.9 Save Device

3.2.4 Device Edit

In device list, you can perform the following operations to device: select, delete, check its status.

- **Select device**

Both in SYSTEM and INPUT page, click to select a device, the background of the device changes in dark.

- **Delete device**

Click **Delete** button  beside the target device in device list, it will pop up a prompt, as shown in **Figure 3.2.10**, click **OK** to delete the device, otherwise, click **Cancel** to cancel the deletion operation.

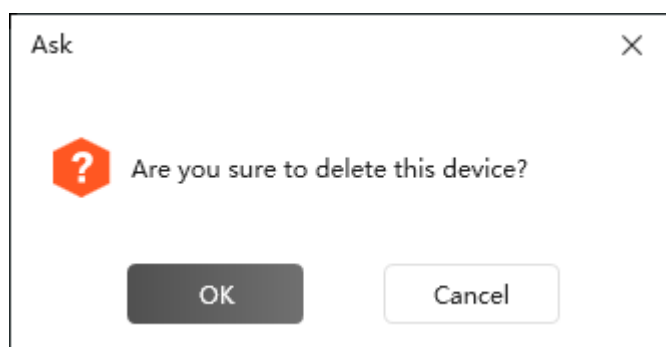



Figure 3.2.10 Prompt for Deleting Device

■ Check device status

In device list, you can check the status of the device by its status icon. The online status icon is , and the offline status icon is .

3.2.5 Device Backup and Import

Select **Import/Backup** command in system page to copy or backup the data on input, layout and system, etc.

3.2.5.1 Backup

Use Device Backup command to export the data of input, layout or system.

Click **Backup** button  at the top of the working area in system page, it will pop up the Device Backup dialog box, as shown in Figure 3.2.11:

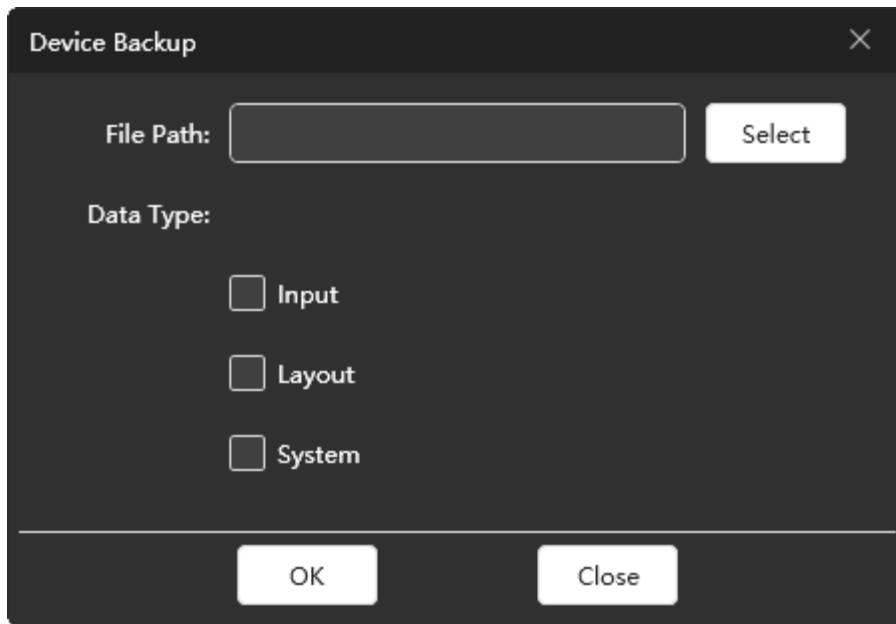

Figure 3.2.11 Device Backup Dialog Box

Click the **Select** button to choose the directory and file name of the backup file, and the suffix of the file is “.bac”. Then check the data type from **Input**, **Layout** and **System** checkbox, you can select one or more kind of data to export.

Click **OK** button, it will execute the export operation. It will pop up export successfully prompt, click **OK** to complete the device backup operation.

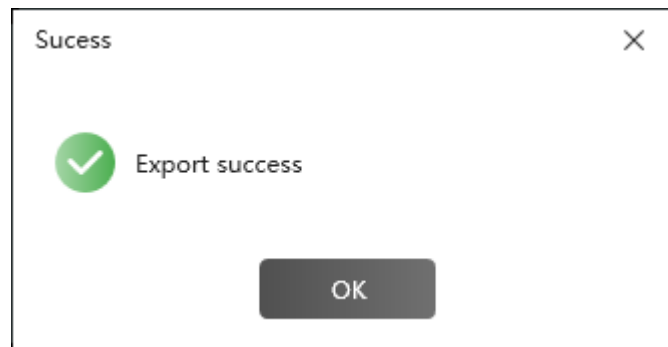



Figure 3.2.12 Prompt for Successful Export

3.2.5.2 Import

Use the Device Import command to import the data of input, layout or system.

Click **Import** button  at the top of the working area in system page, it will pop up the import dialog box, as shown in **Figure 3.2.13**:

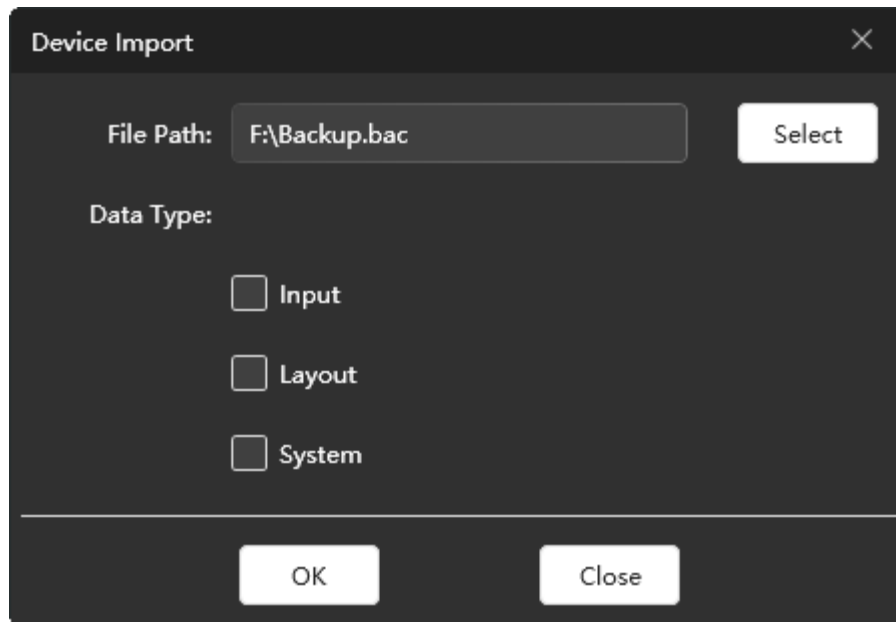

Figure 3.2.13 Import Dialog Box

Click **Select** button to select a file to import, it will pop up the import dialog box, click **Open** button to confirm the selection.

Then choose Data Type to import, and click **OK** button to start the import operation. It will display a prompt, as shown in **Figure 3.2.14**. Click **OK** to complete the data import.

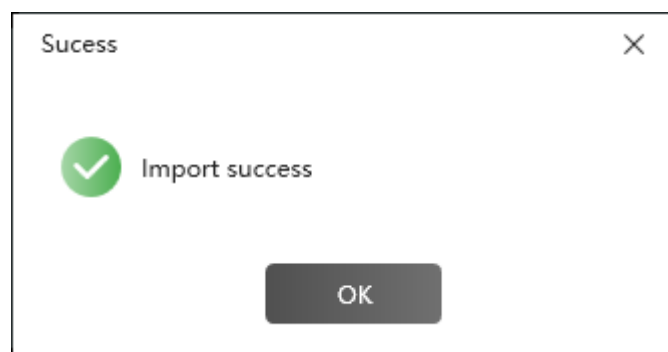

Figure 3.2.14 Prompt for Successful Import

3.3 Input Configuration

The input configuration window shows the signal sources information getting from the connected device.

Click **INPUT** tab in the title bar of software interface, it will display the input list in working area, and the device list in left pane, as shown in **Figure 3.3.1**:

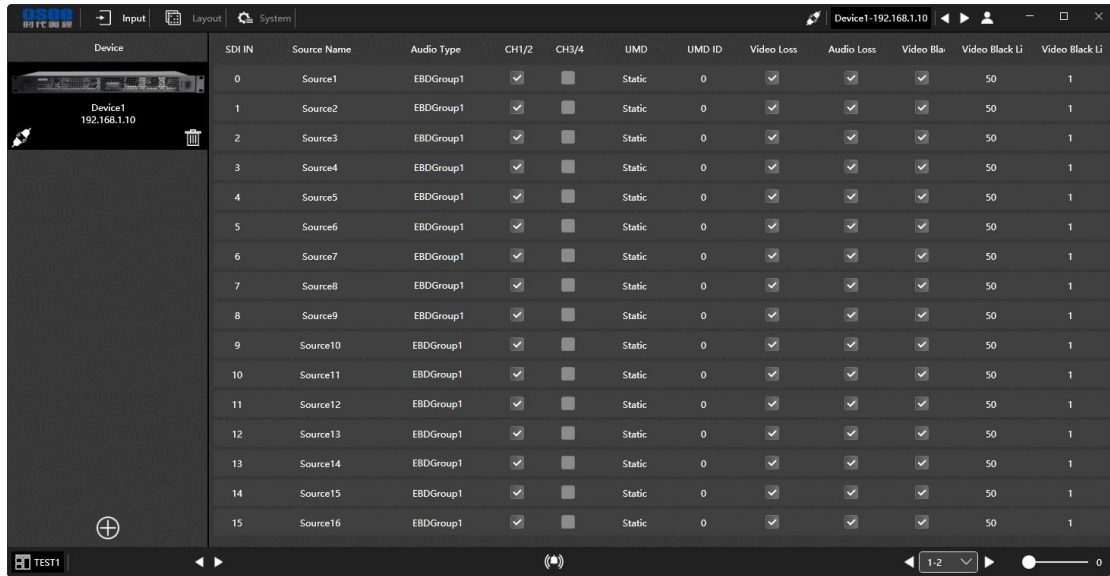

Figure 3.3.1 IN&OUT Configuration Window

As shown in **Figure 3.3.1**, each input signal has these properties: **ID (SDI IN)**, **Source Name**, **Audio Type**, **CH1/2**, **CH3/4**, **UMD**, **UMD ID**, **Video Loss**, **Audio Loss**, **Video Black**, **Video Black Limit1** and **Video Black Limit 2**.

■ **Source Configuration**

The input items that could be configured are listed in this table, as shown in **Figure 3.3.2**:

SDI IN	Source Name	Audio Type	CH1/2	CH3/4	UMD	UMD ID	Video Loss	Audio Loss	Video Bla	Video Black Li	Video Black Li
0	Source1	EBDGroup1	<input checked="" type="checkbox"/>	<input type="checkbox"/>	Static	0	<input checked="" type="checkbox"/>	<input checked="" type="checkbox"/>	<input checked="" type="checkbox"/>	50	1
1	Source2	EBDGroup1	<input checked="" type="checkbox"/>	<input type="checkbox"/>	Static	0	<input checked="" type="checkbox"/>	<input checked="" type="checkbox"/>	<input checked="" type="checkbox"/>	50	1
2	Source3	EBDGroup1	<input checked="" type="checkbox"/>	<input type="checkbox"/>	Static	0	<input checked="" type="checkbox"/>	<input checked="" type="checkbox"/>	<input checked="" type="checkbox"/>	50	1
3	Source4	EBDGroup1	<input checked="" type="checkbox"/>	<input type="checkbox"/>	Static	0	<input checked="" type="checkbox"/>	<input checked="" type="checkbox"/>	<input checked="" type="checkbox"/>	50	1
4	Source5	EBDGroup1	<input checked="" type="checkbox"/>	<input type="checkbox"/>	Static	0	<input checked="" type="checkbox"/>	<input checked="" type="checkbox"/>	<input checked="" type="checkbox"/>	50	1
5	Source6	EBDGroup1	<input checked="" type="checkbox"/>	<input type="checkbox"/>	Static	0	<input checked="" type="checkbox"/>	<input checked="" type="checkbox"/>	<input checked="" type="checkbox"/>	50	1
6	Source7	EBDGroup1	<input checked="" type="checkbox"/>	<input type="checkbox"/>	Static	0	<input checked="" type="checkbox"/>	<input checked="" type="checkbox"/>	<input checked="" type="checkbox"/>	50	1
7	Source8	EBDGroup1	<input checked="" type="checkbox"/>	<input type="checkbox"/>	Static	0	<input checked="" type="checkbox"/>	<input checked="" type="checkbox"/>	<input checked="" type="checkbox"/>	50	1
8	Source9	EBDGroup1	<input checked="" type="checkbox"/>	<input type="checkbox"/>	Static	0	<input checked="" type="checkbox"/>	<input checked="" type="checkbox"/>	<input checked="" type="checkbox"/>	50	1
9	Source10	EBDGroup1	<input checked="" type="checkbox"/>	<input type="checkbox"/>	Static	0	<input checked="" type="checkbox"/>	<input checked="" type="checkbox"/>	<input checked="" type="checkbox"/>	50	1
10	Source11	EBDGroup1	<input checked="" type="checkbox"/>	<input type="checkbox"/>	Static	0	<input checked="" type="checkbox"/>	<input checked="" type="checkbox"/>	<input checked="" type="checkbox"/>	50	1
11	Source12	EBDGroup1	<input checked="" type="checkbox"/>	<input type="checkbox"/>	Static	0	<input checked="" type="checkbox"/>	<input checked="" type="checkbox"/>	<input checked="" type="checkbox"/>	50	1
12	Source13	EBDGroup1	<input checked="" type="checkbox"/>	<input type="checkbox"/>	Static	0	<input checked="" type="checkbox"/>	<input checked="" type="checkbox"/>	<input checked="" type="checkbox"/>	50	1
13	Source14	EBDGroup1	<input checked="" type="checkbox"/>	<input type="checkbox"/>	Static	0	<input checked="" type="checkbox"/>	<input checked="" type="checkbox"/>	<input checked="" type="checkbox"/>	50	1
14	Source15	EBDGroup1	<input checked="" type="checkbox"/>	<input type="checkbox"/>	Static	0	<input checked="" type="checkbox"/>	<input checked="" type="checkbox"/>	<input checked="" type="checkbox"/>	50	1
15	Source16	EBDGroup1	<input checked="" type="checkbox"/>	<input type="checkbox"/>	Static	0	<input checked="" type="checkbox"/>	<input checked="" type="checkbox"/>	<input checked="" type="checkbox"/>	50	1

Figure 3.3.2 Source Configuration Table

Click the Audio Type cell to show the drop down list, each audio meter contains 4 groups of audio channels, each group contains four channels.

For example: CH1/2 contains the first and the second channel audio information, and so on.

Items	Description	Comments
ID	The ID number of the input interface, it is not editable and allocated by the system, the value is "interface number".	0~15
Source Name	Set the source name in this cell, and the default name is composed of character "Source" and the connector number. Double-click the default name to change it.	Source name is used to be part of UMD characters.
Audio Meter1	Set audio source for this input, you can select among these items: Analog Audio, EBDGroup1, EBDGroup2, EBDGroup3, EBDGroup4	--
CH1/2	Select audio channel CH1/2 as the audio source	Yes/No
CH3/4	Select audio channel CH3/4 as the audio source	Yes/No
UMD Type	Set the type for UMD source as static or dynamic. If it is static, the UMD content will be set as source name + window name; If it is dynamic, the UMD content will be the value received from the TSL protocol	Static
UMD ID	Set the UMD ID	0~256
Left Tally Source	Set the interface number through which will receive the left TALLY source	GPI1 or TSL
Video Loss	Set whether to detect the video loss alarm	Yes/No
Audio Loss	Set whether to detect the audio loss alarm	Yes/No
Video Black	Set whether to detect the video black alarm	Yes/No
Video Black Limit1	Set the threshold of video black alarm, the default is 0	0~100
Video Black Limit2	Set the consecutive frames of video black, the default is 1	1~255

Tips

- The TSL Version selection is set in **DEVICE Info** → **TSL Settings** → **TSL Protocol** item.

3.3.1 Set Source Name

Double-click the **Source Name** cell to modify the name of the input source, and the source name in Layout configuration will be changed synchronously.

SDI I	Source Name
0	Source1
1	Source2

Figure 3.3.3 Rename the Signal Source

The length of source name should not be longer than 48 English characters, and the range is from 0x00 to 0x7F(ASCII), otherwise, there will be prompts as below:

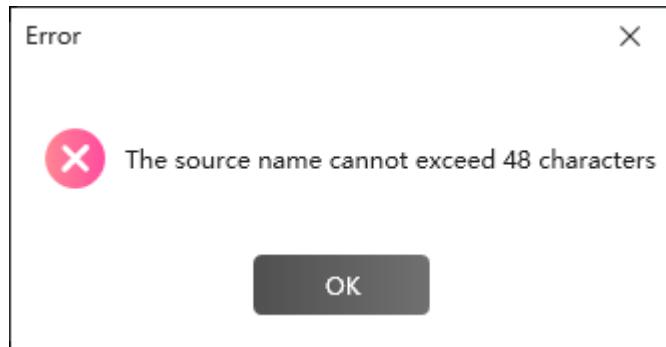

Figure 3.3.4 Error Prompt for Source Name

i Tips

- In the INPUT configuration table, all the cells except ID item could be modified.

3.3.2 Set Audio Source

Set the audio source for an audio meter, each audio source is a group of audio channels which contains the information of two audio channels.

■ Set audio source

Click each audio meter cell to choose an audio channel source from the audio type drop down list, you can select analog audio, or EBD group. When selecting digital audio source, you should tick off the item CH1/2 or CH3/4 as its value, as shown in **Figure 3.3.5**:

SDI IN	Source Name	Audio Type	CH1/2	CH3/4
0	Source1	EBDGroup1	<input checked="" type="checkbox"/>	<input type="checkbox"/>
1	Source2	EBDGroup1	<input checked="" type="checkbox"/>	<input type="checkbox"/>
2	Source3	EBDGroup1	<input checked="" type="checkbox"/>	<input type="checkbox"/>
3	Source4	EBDGroup2	<input checked="" type="checkbox"/>	<input type="checkbox"/>
4	Source6	EBDGroup3	<input checked="" type="checkbox"/>	<input type="checkbox"/>
5	Source6	EBDGroup4	<input checked="" type="checkbox"/>	<input type="checkbox"/>

Figure 3.3.5 Set Audio Channels for an Audio Meter

For example: Set EBDGroup1 for Source1, and tick off CH1/2 and CH3/4, then the audio meter for Source1 in Window1 displays as shown in Figure 3.3.6:

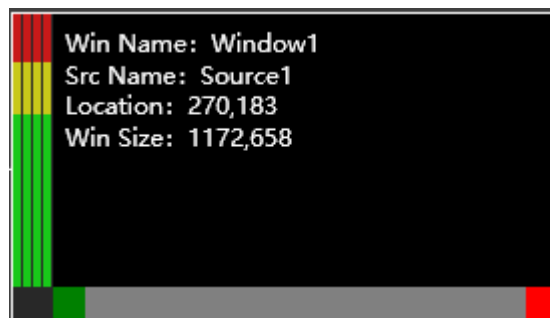

Figure 3.3.6 Audio Meter of Four Channels

Tips

- Each audio meter contains four group of audio information each has four audio channels, and the CH1~CH4 matches the audio meter on monitor window displayed from left to right in sequence.

3.3.3 Set UMD

Set the UMD source through **UMD** and **UMD ID** cell, it could be static characters or dynamic content from TSL protocol.

- Set UMD Source

Set the source for UMD content according to the UMD type as static or dynamic.

- Static UMD: Set the UMD Type as **Static**, then the UMD characters are composed of "Source Name+ Window name". For example: set **Static** as UMD Type for Source1, as shown in Figure 3.3.7, and mapping **Source1** to **Window1**, then the UMD characters display "**Source1 Window1**" in UMD Text area.
- Dynamic UMD: Set the UMD Type as Dynamic, as shown in **Figure 3.3.8**, and enter the address ID in UMD ID cell, and choose TSL 3.1 protocol in system page, then it will receive the UMD text from TSL protocol.

SDI IN	Source Name	UMD	UMD ID
0	Source1	Static	0
1	Source2	Static	0

Figure 3.3.7 Static Source for UMD

SDI IN	Source Name	UMD	UMD ID
0	Source1	TSL	0
1	Source2	Static	0

Figure 3.3.8 Dynamic Source for UMD

The range for TSL port is 0~126. If out of the range when setting UMD ID, it will pop up a prompt, as shown in Figure 3.3.9:

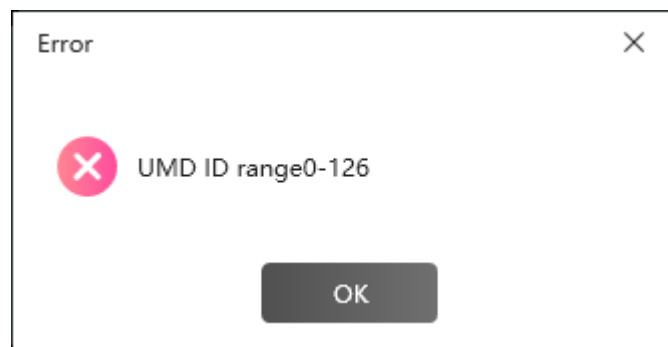

Figure 3.3.9 Prompt for UMD ID Error

3.3.4 Alarm Setting

1. Video alarm and audio alarm

The alarm is divided into video alarm and audio alarm according to the alarm contents.

- Video Alarm: supports video loss and video black.
- Audio Alarm: supports audio loss.

Each input interface has video alarm and audio alarm, and when the value of the alarm parameter meets the alarm condition, it will generate the alarm event.

2. Alarm Switch

The alarm switch is divided into alarm action switch and alarm display switch according to its functionality. The former is used to decide whether to detect the alarm that has happen or not, the latter is used to decide whether the alarm information will be display or not. The differences are as below:

Alarm Action Switch

The alarm action switch is used to set whether the multi-image processor processes and collects the selected alarm or not. If the settings are positive, it will process and collect the alarm information of the selected alarm event, then record the alarm data, otherwise, if the settings are negative, or it will not process and collect the alarm information, and there will be no alarm data.

In input configuration window, select alarm settings.

- Setting for Alarm Action Switch

You can set the alarm action switches for video alarm and audio alarm in Input page.

Click **Video Loss/ Audio Loss/ Video Black** items in INPUT page, as shown in Figure 3.3.10:

SDI IN	Source Name	Video Loss	Audio Loss	Video Black	Video Black Limit1	Video Black Limit2
0	Source1	<input checked="" type="checkbox"/>	<input checked="" type="checkbox"/>	<input checked="" type="checkbox"/>	50	1
1	Source2	<input checked="" type="checkbox"/>	<input checked="" type="checkbox"/>	<input checked="" type="checkbox"/>	50	1
2	Source3	<input checked="" type="checkbox"/>	<input checked="" type="checkbox"/>	<input checked="" type="checkbox"/>	50	1

Figure 3.3.10 Alarm Switches

The relationship of the alarm action switches and the corresponding parameter are shown as in Table 3.3-1 :

Table 3.3-1 The Alarm Action Switches and Alarm Parameters

Alarm Type	Alarm Property	Value Range	Default	Description
Video Alarm	Video Loss	Yes/No	Yes	Enable/Disable video loss alarm
	Video Black	Yes/No	No	Enable/Disable video black alarm
	Video Black Limit1	0~100	0	Set the sensitivity for video black alarm
	Video Black Limit2	1~255	1	Set the consecutive frames of video black when detecting video black
Audio Alarm	Audio Loss	Yes/No	Yes	Enable/Disable audio loss alarm

Tips

- The alarm parameters whose value should be set as Yes or No are the corresponding alarm action switches. When the alarm action switch is set to Yes, it will process and collect the alarm information, and the other parameters (limitation) are valid.
- The threshold for video alarms(Video Black Limitation1): the higher percentage the threshold is, the easier the corresponding alarm happens.

■ For example: Start up the alarm detection

As shown in Figure 3.3.11, set the video and audio loss alarm to Source1.

Operation: Choose the Video Loss and Audio Loss item, as shown in Figure 3.3.11:

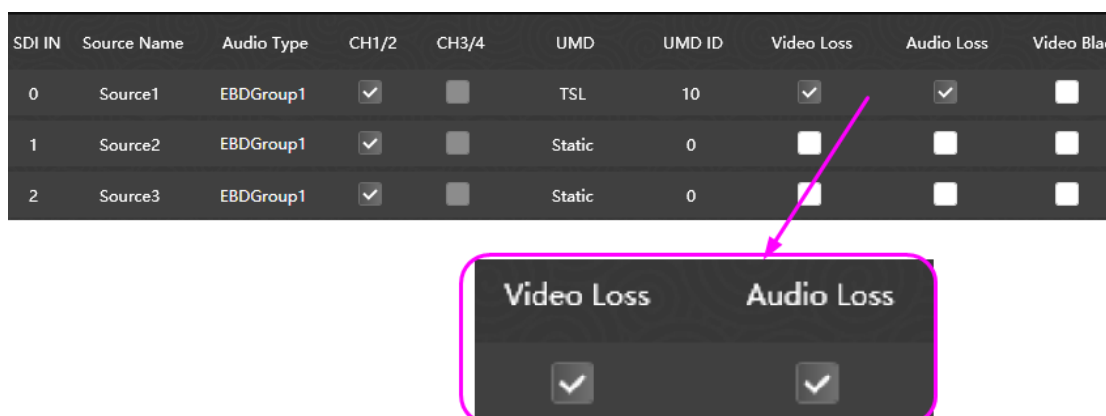
Figure 3.3.11 Set Video and Audio Loss Alarm

Alarm Display Switch

The alarm display switch must cooperated with the alarm action switch, that is, after the alarm action switch is enabled, if the alarm display switch was enabled, it will display the alarm information on the display screen.

i Tips

- The prerequisite for the alarm display switch is the corresponding alarm action switch. When the alarm action switch is enabled, the alarm display switch is effect to the display of the alarm information if it is set as enabled, otherwise, if the alarm action switch is disabled, the alarm display switch will have no effect to the display of the alarm information although it is set as enabled.

According to the different types of the alarm output devices, the alarm display switch contains the following types:

- Alarm display switch about screen show: it is used to control whether to display alarm information on screens.

Set it at: Layout → monitor's **Element Prop** pane→**Alarm** table, as shown in Figure 3.3.12:

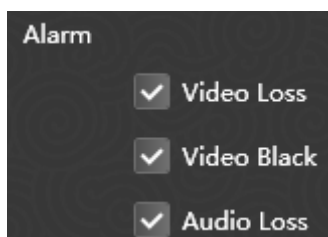

Figure 3.3.12 Alarm Display Switch

i Tips

- The audio alarm action switch is divided into 16 selection box for each audio channel, but the audio alarm display switch is only one for the 16-channels audio signal.

The relationship of the alarm action switch and the alarm display switch are listed as below:

Table 3.3-2 The Alarm Display Switches and Alarm Parameters

Alarm Type	Alarm Action Switch	Alarm Display Switch(on screen)
------------	---------------------	---------------------------------

Video Alarm	Video Loss	Video Loss Display
	Video Black	Video Black Display
Audio Alarm	Audio Loss	Audio Loss Enable

The logic relationships among all these alarm switches and configurations are as shown in Figure 3.3.13:

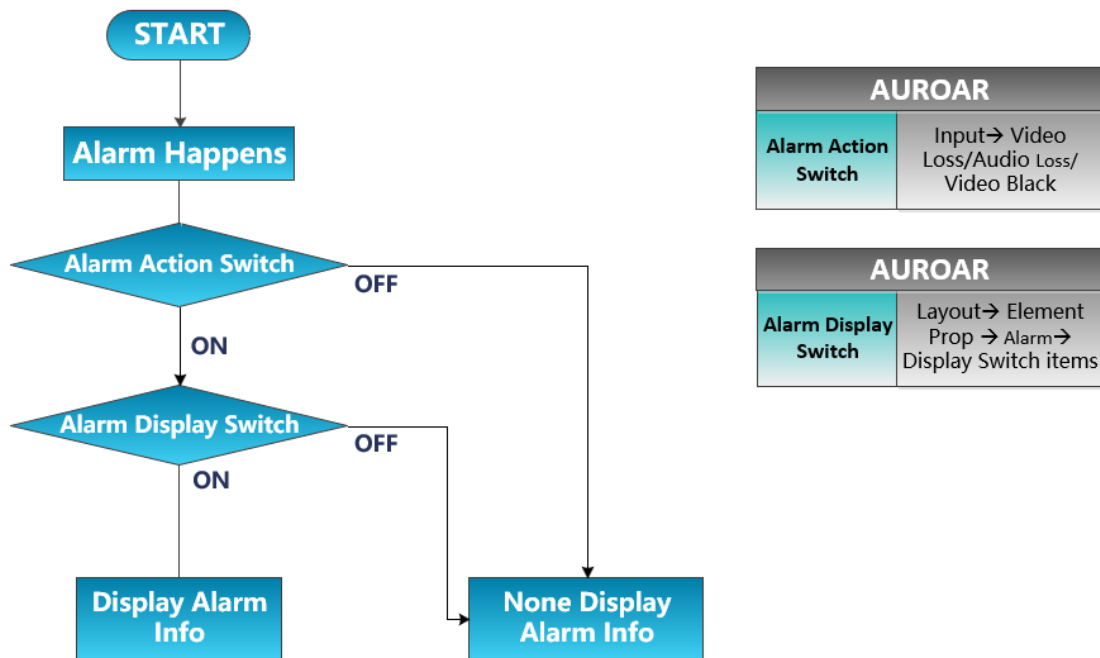

Figure 3.3.13 Alarm Relationships

For example: select **VIDEO LOSS** item for Source1 in Input page, and select **Alarm → VIDEO LOSS** in Element Prop for Window1, and mapping Source1 to Window1, then there will the video loss prompt if Source1 is loss, the alarm prompt is as shown in Figure 3.3.14 :



Figure 3.3.14 Alarm Prompt

3. Alarm Log

It provides alarm log to record the alarm events, and you can filter your alarm information by any one of the alarm header in alarm log.

The newest alarm info will be display in the status bar, as shown in Figure 3.3.15:

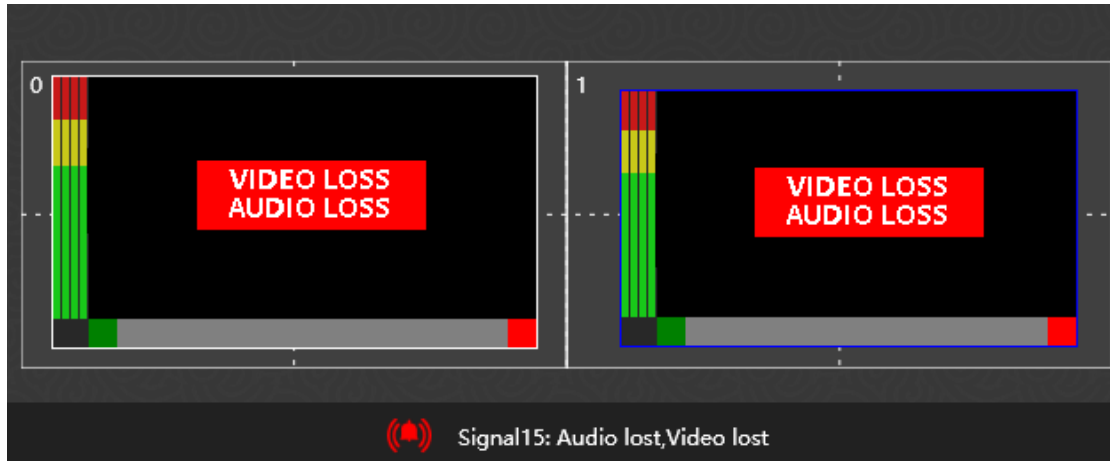



Figure 3.3.15 Alarm Prompts

Click the alarm log icon  in the status bar, it will pop up the alarm log dialog box, as shown in

Alarm Log			
Alarm Time: 2021/3/15 - 2021/3/16			
ID	Source ID	Alarm Content	Alarm Time
5123	15	Signal15: Audio lost,Video lost	2021-03-16 11:26:08
5122	14	Signal14: Audio lost,Video lost	2021-03-16 11:26:08
5121	13	Signal13: Audio lost,Video lost	2021-03-16 11:26:08
5120	12	Signal12: Audio lost,Video lost	2021-03-16 11:26:08
5119	11	Signal11: Audio lost,Video lost	2021-03-16 11:26:07
5118	10	Signal10: Audio lost,Video lost	2021-03-16 11:26:07
5117	9	Signal9: Audio lost,Video lost	2021-03-16 11:26:07
5116	8	Signal8: Audio lost,Video lost	2021-03-16 11:26:07
5115	7	Signal7: Audio lost,Video lost	2021-03-16 11:26:07
5114	6	Signal6: Audio lost,Video lost	2021-03-16 11:26:07

Figure 3.3.16 Alarm Log

You can set the start time and end time in the top of this dialog box to filter the alarm messages in the list, and each alarm message contains these parameters: ID, Source ID, Alarm Content and Alarm Time.

Click each header of the alarm log list, such as ID, Source ID or Alarm Time, it will arrange the list in the corresponding item.

Tips

- Only the signal source whose alarm action switch is on could be recorded into the alarm log.

3.4 Layout Configuration

It will introduce the following subjects in Layout Configuration:

- Template Configuration
- Tool Bar
- Elements Properties
- Elements Layouts

Click **Layout** tab in the title bar to switch to the layout configuration window, as shown in Figure 3.4.1, the left system pane contains **Sources** and **Templates** List, and the right property pane contains Elements Properties and Model Properties. And there is the current active template blank by default in working area.

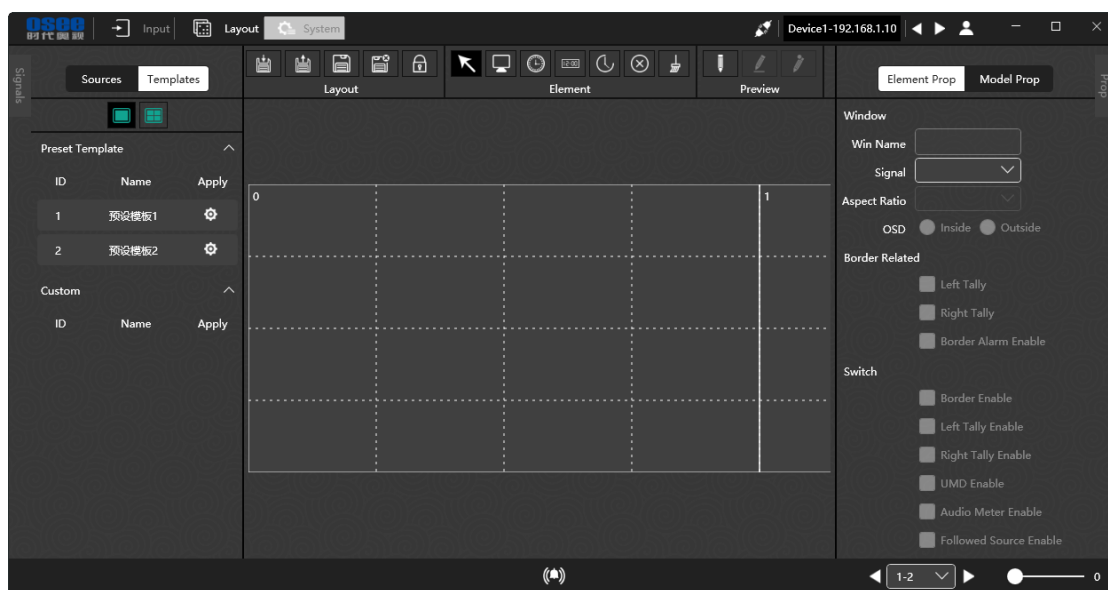



Figure 3.4.1 Layout Window

Tips

- The tool buttons in the top of the working area of Layout window are only available when LOCK button  is set to Unlock. Click the LOCK button to change it into UNLOCK status , the template is unlocked, and you can use the other tool buttons. No further description below in this section.
-

The instructions are as below.

3.4.1 Template Configuration

It will introduce the creation, open, deletion and other operations for template configuration.

Tips

- There is a blank template in in working area by default, and this is the current active template.
-

3.4.1.1 Create a Template

Create a template by preset template or customize your own template.

- Method1: it provides some preset templates in the left templates pane, and it is easy to use this preset to create your desired layout.

First, select a preset template in the Template list, then click **Apply** button to apply this preset in the working area, as shown in Figure 3.4.2, after that, add elements you need in this preset.

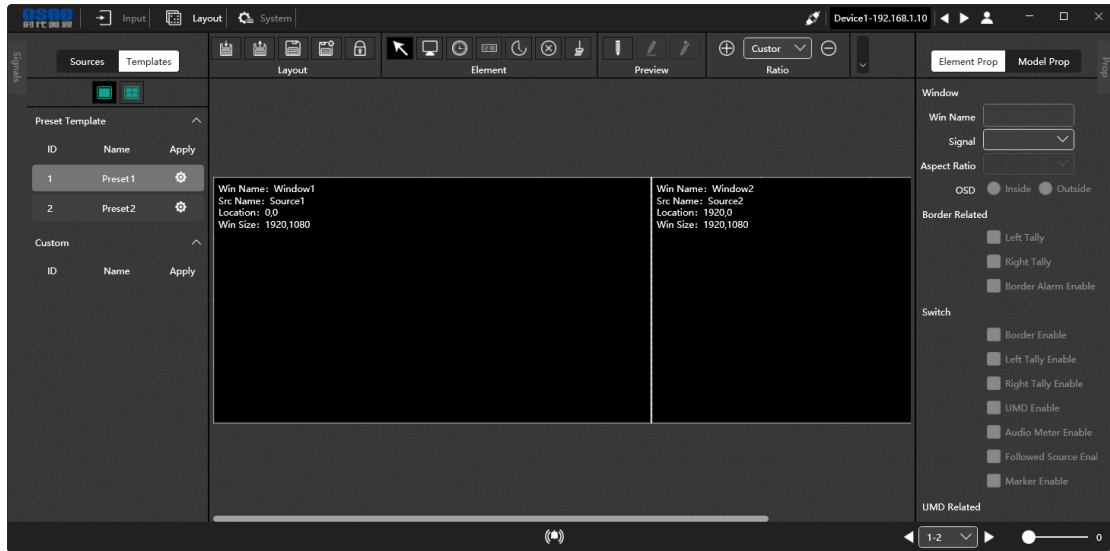

Figure 3.4.2 Apply Preset Template

- Method2: create a customized template based on the blank template in working area.

There is the blank active template in the working area by default, so press the tools in Element area to draw monitor window, analog clock, etc. Click an element button, drag and draw a big rectangle to add a window, release the left mouse button and add it into the template, as shown in Figure 3.4.3:

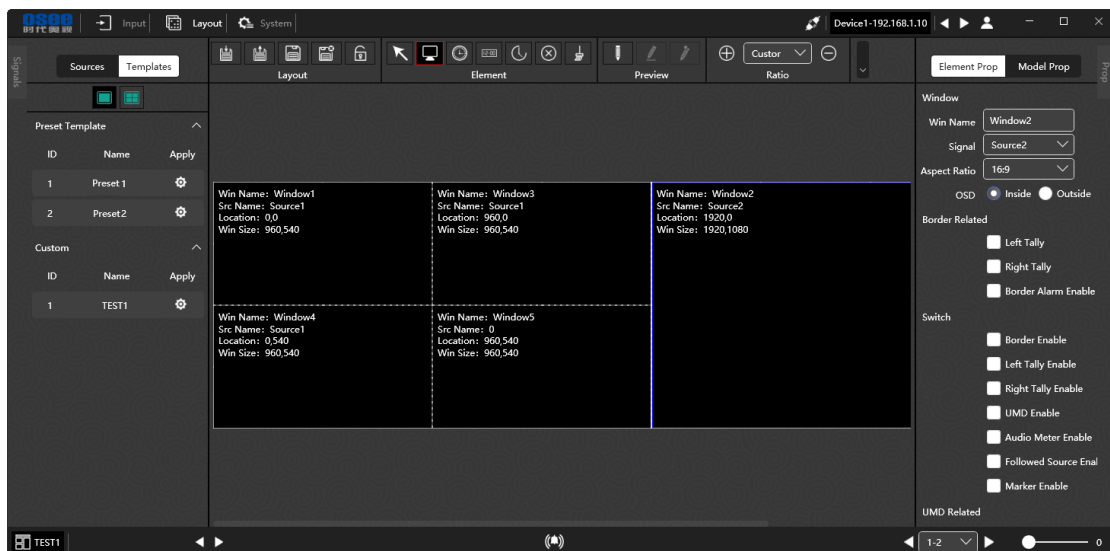



Figure 3.4.3 Create a Template

3.4.1.2 Save a Template

- Save current template

Click Save button  in the tool bar, it will prompt a Save Template dialog box, as shown in Figure 3.4.4. Select the target index ID, and enter a template name in Name field, then press **OK** button to confirm the input.

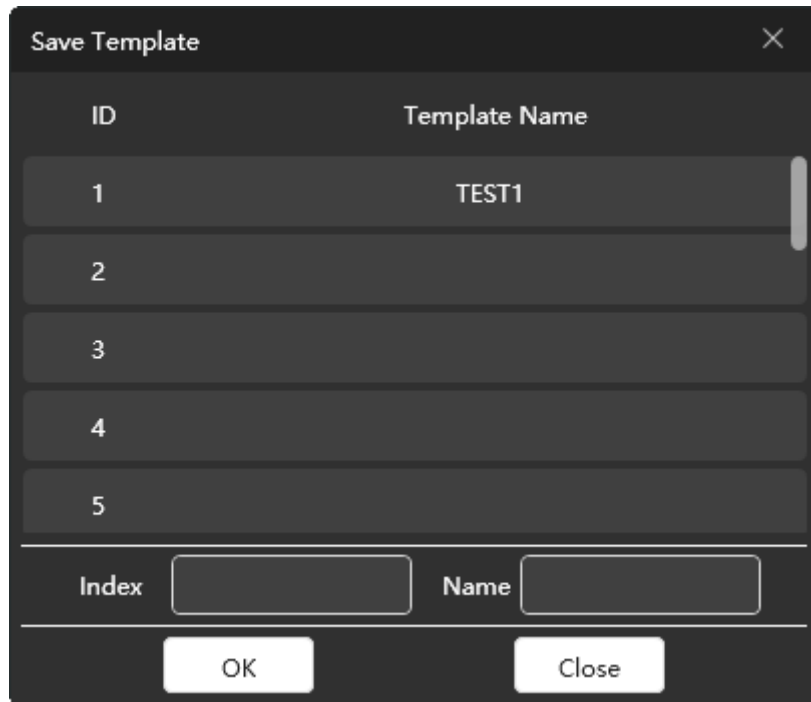

Figure 3.4.4 Save Prompt

And there will be a successful added prompt, as shown in Figure 3.4.5:

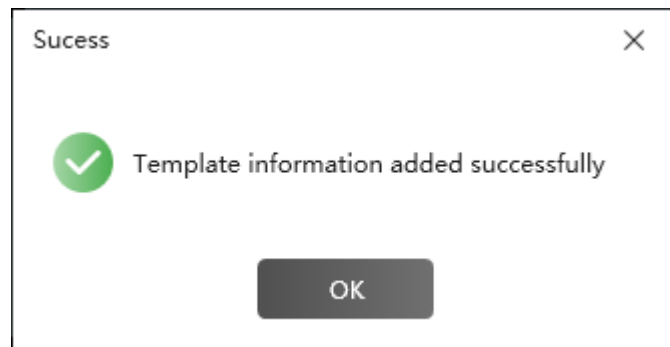

Figure 3.4.5 Prompt for Adding a Template

And the template name will be added as a tab button at the bottom of the template list in status bar, as shown in Figure 3.4.6, click the tab, and you can open the corresponding template as the current active template.

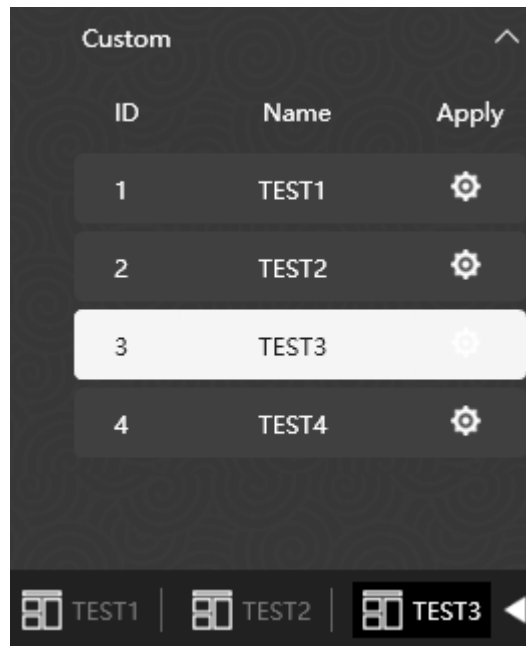

Figure 3.4.6 Template Tabs

Click the left or right arrow  beside the template tabs to turn page.

i Tips

- The template name can be composed of any characters, and the length should not exceed 48 English characters(16 Chinese characters).
- Double-click the template name in the customized template list to modify the name, and click other place to confirm the modification.

3.4.1.3 Open a Template

You can open a template from the template list.

Click a template in the template list and click the Apply button , or click the customized template tab at the bottom of the template list in status bar, the template will be opened in the working area.

3.4.1.4 Delete a Template

Click **Delete** button  in the tool bar to delete the current template in working area. And it will pop up a prompt for confirm the deletion, as shown in Figure 3.4.7. Click **OK** to delete the template, or click No to

cancel the deletion.

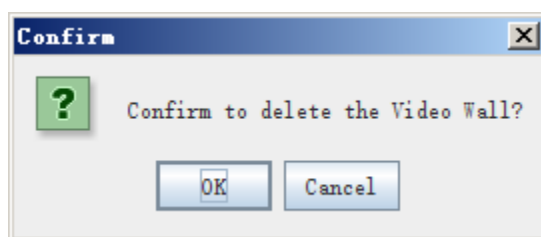

Figure 3.4.7 Prompt for Delete a Template

3.4.1.5 Model Properties

You can check or modify the properties of a template in its Model Properties pane.

The property pane at the right area of the software interface contains two tabs: **Elements Prop** and **Model Prop**, click the tab to display the corresponding property pane.

Operation: click Model Prop tab to display the current template properties, as shown in **Figure 3.4.8:**

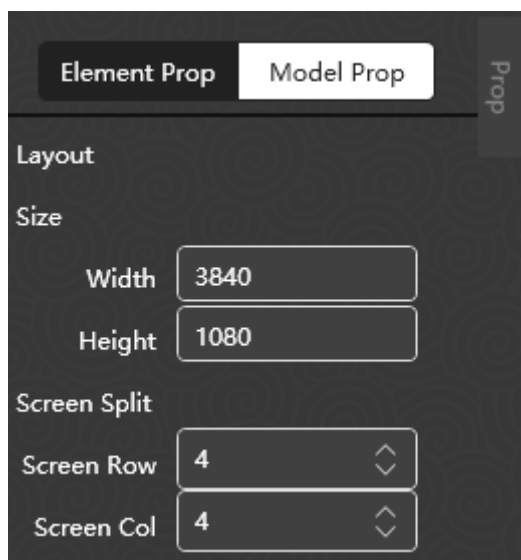

Figure 3.4.8 Model Properties

The model properties contain the following items:

Item		Value Range	Default	Description
Size	Width	0~3840	--	The template width in horizontal direction.
	Height	0~2160	--	The template height in horizontal direction.
Screen Split	Screen Row	1~4	1	Set the splitters number for a screen in horizontal direction.

Item	Value Range	Default	Description
Screen Col	1~4	1	Set the splitters number for a screen in vertical direction.

Tips

- The screens of a template are divided by white lines. The dotted line are used to align, and the rectangle surrounded with the solid line is corresponding to a physical screen indeed. The size of screen displayed is Width*Height.
- The split area number added in horizontal direction or vertical direction of the template wall can't exceed 4*4.
- The template size could not be modified by Width or Height items, this settings is synchronized with the output settings in **System→ Device Info→Output Settings→Resolution**, the relationship is as shown in the table below.
- If you have modify the **Output Settings** of the device, please note that the templates you have made for the original output settings may be changed, and no longer fit for the new one.

Table 3.4-1 Relationship between Output Resolution and Template Size

Resolution	Template Size
1080i50, 1080i60 1080P50, 1080P60	3840*1080
2160P25, 2160P30 2160P50, 2160P60	3840*2160

For example: Set both the Screen Row and the Screen Column to be two, the screen in a template wall is as shown in **Figure 3.4.9**, each screen is divided by the splitter into 2*2 cells.



Figure 3.4.9 The Splitters-2*2



Tips

- The splitter assists in editing element windows such as move, align, adjust windows and so on.
-

3.4.1.6 Other Operations to Template

1. Preview Mode

Click the **Templates** tab at the left pane of the layout configuration window, and it lists the templates pane. The template pane is divided into the upper part and the lower part, corresponding to the defaults and the customized separately.

There are two preview modes for template in template list, one is list , and the other is view .

Click **List** icon  in the templates list, as shown in Figure 3.4.10, the default preview mode is List, and it contains the template parameters: **ID**, **Name** and **Apply** button. Click the apply button besides a template, it will apply this template to the working area, and change it to the current active template.

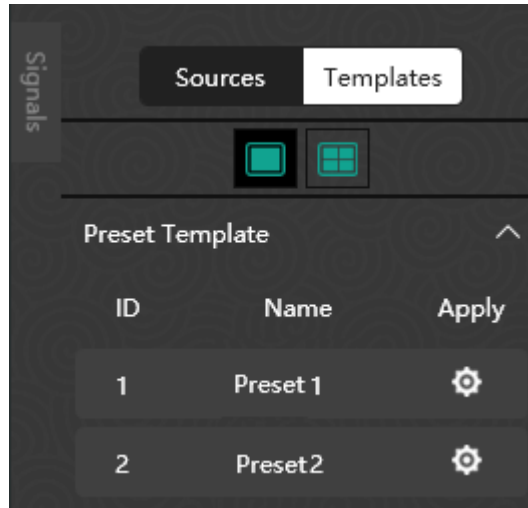



Figure 3.4.10 *Templates in List*

Click **View** icon , it will display the template list in thumbnail, as shown in Figure 3.4.11:

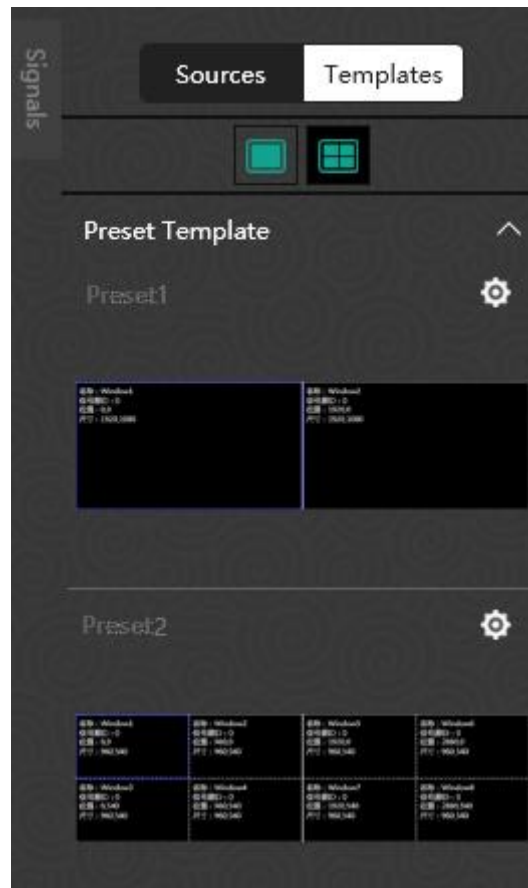



Figure 3.4.11 *Templates in View*

Tips

- The preset templates are defined by the system, unmodified or deleted, and the customized templates could be defined, modified and deleted by the customers.
- Each template with different resolutions can support up to 16 monitor windows, not including clock element windows.

2. Import Template

Create a template by importing a template.

Click **Import** button  at the tool bar of the Layout area, it will pop up **Import Template** dialog box to restore template from the backup files, as shown in Figure 3.4.12:

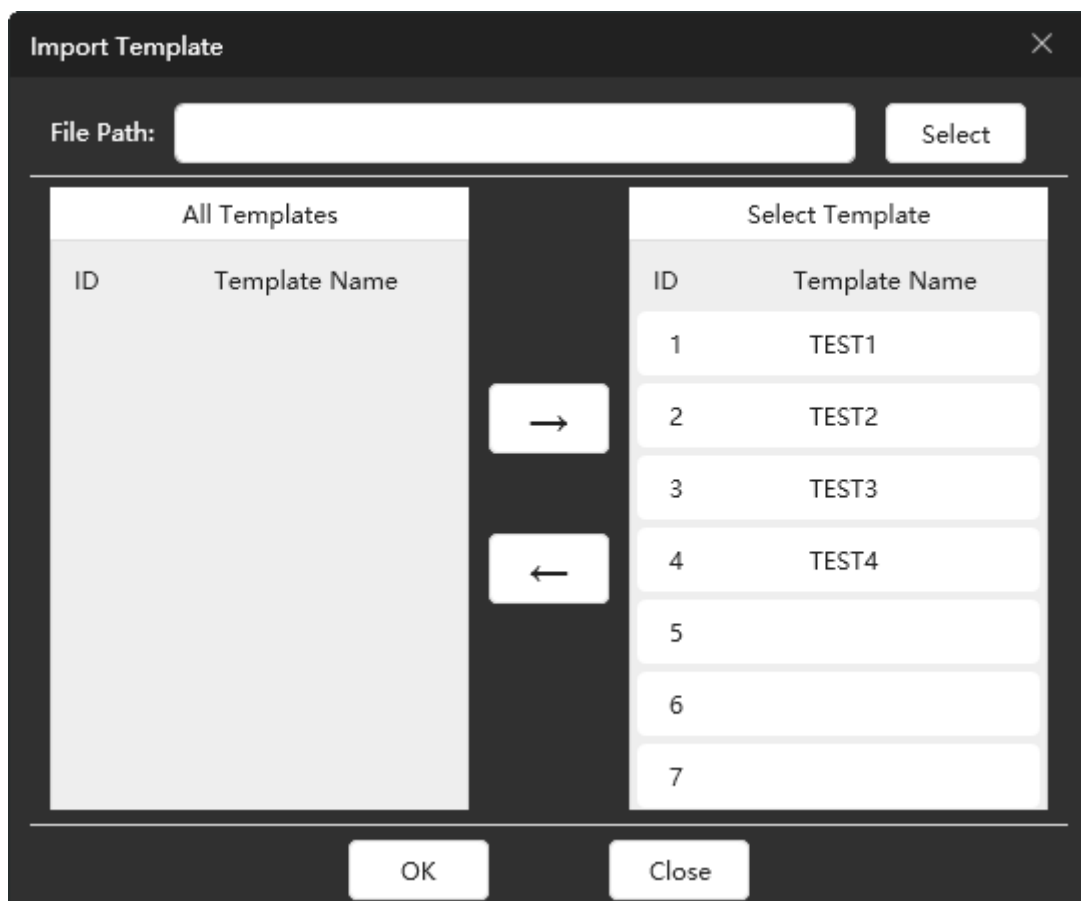

Figure 3.4.12 Import Template Dialog Box

First, click **Select** button to choose a file, and click **OK**, then it will load all the templates saved in the file in left pane, select a template from the All

Templates list, and press right arrow button to add the selected one into the Select Template list, you can choose any one of the target ID as the target position. Click **OK** to confirm the import.

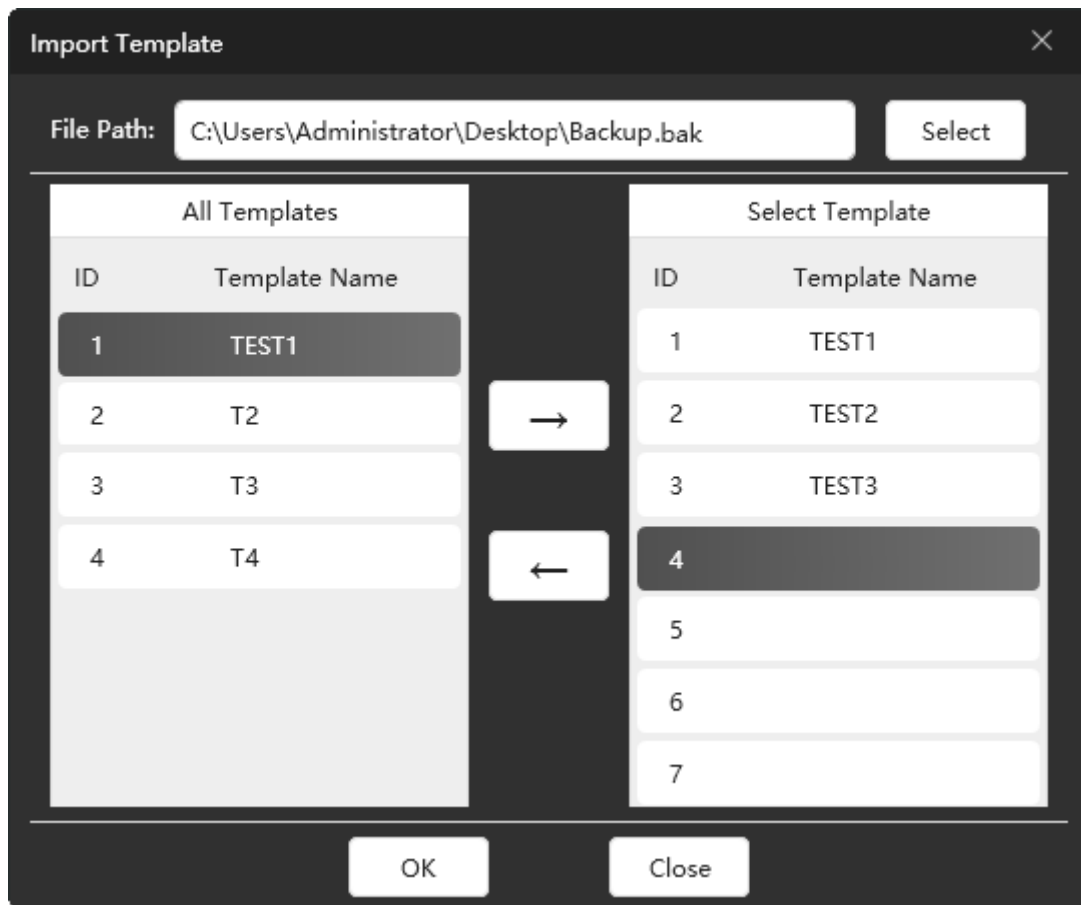



Figure 3.4.13 Select a Target ID

i Tips

- The target selected ID will be in highlighted.
- If you want to change the target template ID, you can remove the one added in the right list back to the left list by the left arrow, then reselect a target ID, and select the template in the left list, then press right arrow button to add the one into the new ID in the Select Template list.
- The import and export of templates operations will not make any effect on the current active template in the working area. If you have any changes not saved, you can do it after the import and export operation.

3. Export Template

Save the selected templates to a desired file in a directory by exporting template.

Click **Export** button  at the tool bar of the Layout area, it will pop up **Export Template** dialog box to save the selected templates to a file, as shown in Figure 3.4.12:

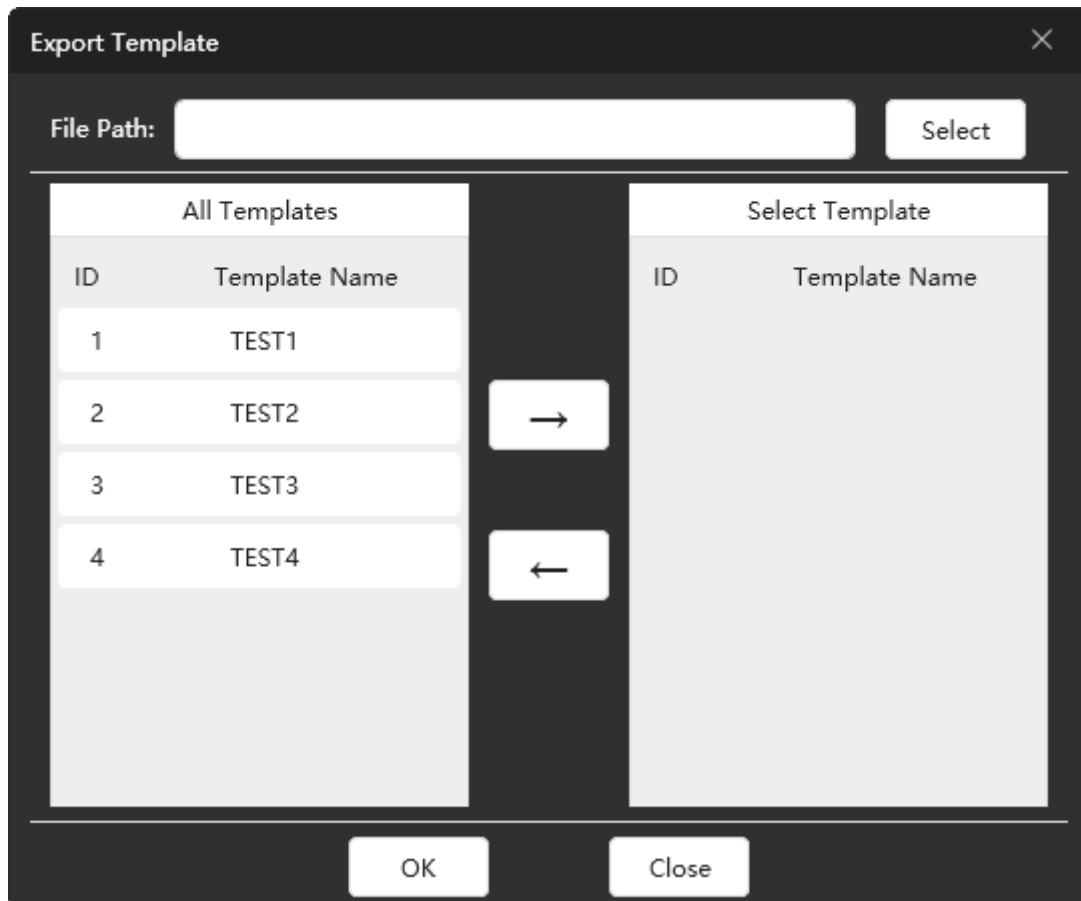



Figure 3.4.14 Export Template Dialog Box





First, click **Select** button to choose a file path and set the backup file name, and click **OK**, then select some templates from the All Templates list to export, and press right arrow button to add the selected one into the Select Template list. Click **OK** to confirm the export.

4. Switch Template

In online controller interface, the screen wall shows the template currently displayed in working area, that's the active template. If you want to switch another one, choose a template in the template list, and press the **Apply** button  beside it, it will switch the selected one on the screen wall instead.

■ Preview-switch

In online status, if you want to modify the current template without displaying the result synchronizing on the screen wall, we provide Preview function.

Click enter **Preview** button  in tool bar to enter into the preview mode, then the changes on the current template in working area will not take any effect on the active template displaying on the physical screen wall. Then, after complete the modification, click **Apply Preview** button  to preview the modification on the physical screen wall, at last, click Exit button  to quit the preview mode, then click Save button  to save the changes to the template.

5. Source Mapping and Switch

You should connect a signal source for the selected monitor window element. Click the Source List in system pane of the Layout configuration window, select a signal source node, and drag it to a desired monitor window in working area, release the mouse button to complete the connection.

If you need to reconnect a new signal source to the target monitor window, then select a new signal source, and drag it to the target monitor window to replace the old one.

For example: select Source1 in Source list, press the left mouse button down, and drag it onto the Window1, you can see the Src Name in Window1 is changed to Source1, as shown in **Figure 3.4.15**:

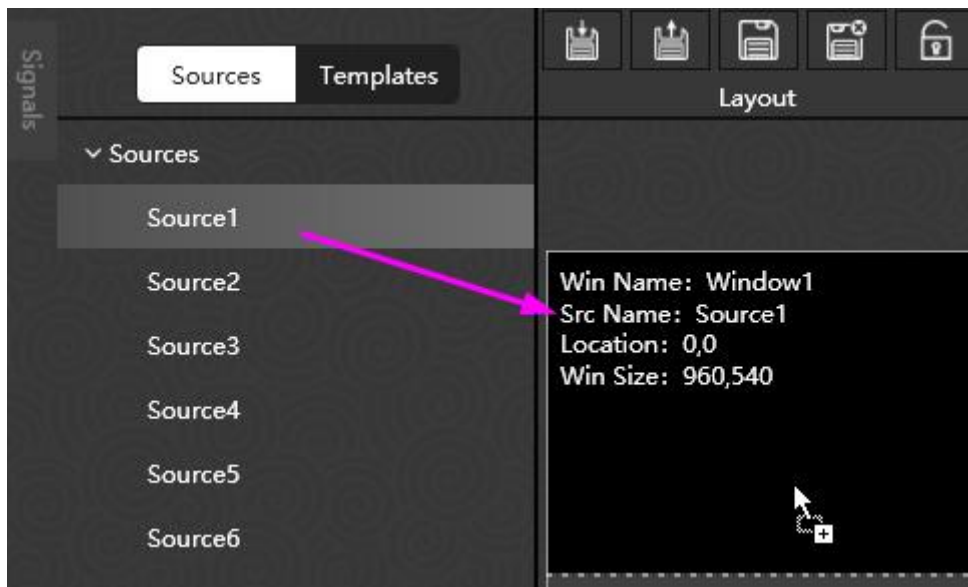



Figure 3.4.15 Connect a Signal Source for a Monitor Window

3.4.1.7 Preset Templates

For simplify and facilitate the process of template configuration, we

provide some preset templates in the Templates pane.

There are two preview modes for template in template list, one is list , and the other is view , as shown in **Figure 3.4.16**:

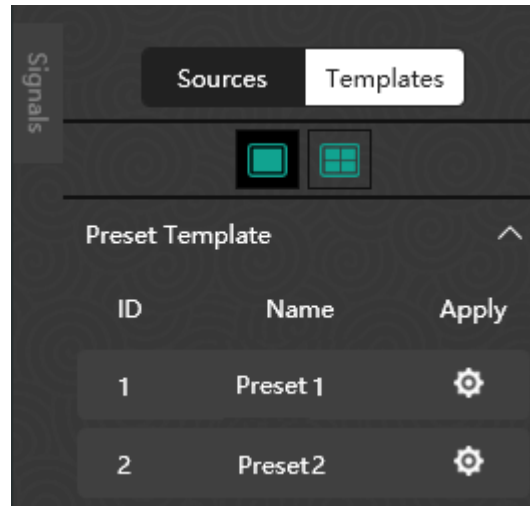



Figure 3.4.16 Template List

Click  button to display the preset template in thumbnail. Select a template in the Templates pane, and click **Apply** button  to display this template applied as current layout in working area.

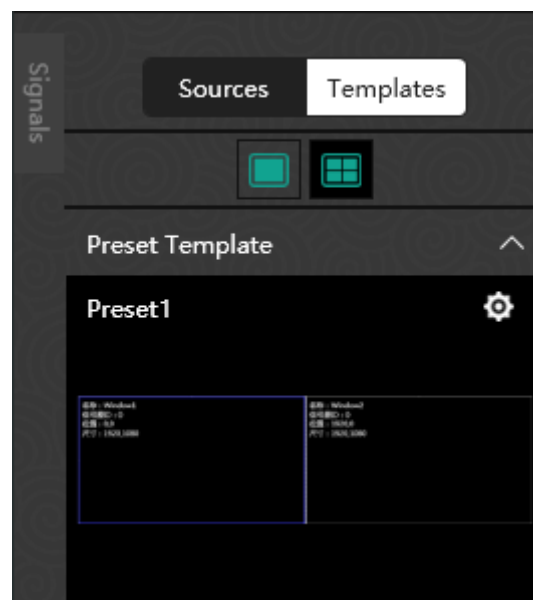

Figure 3.4.17 Prompt for Apply a Template

3.4.2 Tool Bar

1. Tool Sort

Argos provides various tools for Layout configuration, and the tools are used for drawing and editing for the layout, as shown in Figure 3.4.18, the tools are showed as shortcut buttons, click the button to active the corresponding command.

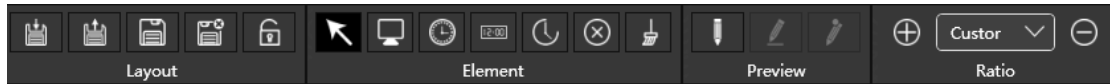

Figure 3.4.18 Tool Bar for Layout Configuration

There will be a tip besides the tool button when moving the mouse cursor on the button, as shown in **Figure 3.4.19**:

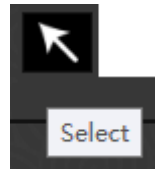

Figure 3.4.19 Tip on Tool Button

There are following statuses for the tool button:

- **Unavailable:** the tool button is in grey that is the button can't be used.
- **Available:** if the button is in black and the icon is in white, that is the button is available.

i Tips

- The tools are available in unlock mode.
 - Refer to "2.3.3 Layout Configuration Window" for the details about the shortcut tool buttons in tool bar.
-

3.4.3 Elements Properties







In current active template in working area, you should add various element windows on the screens.

- Element Type

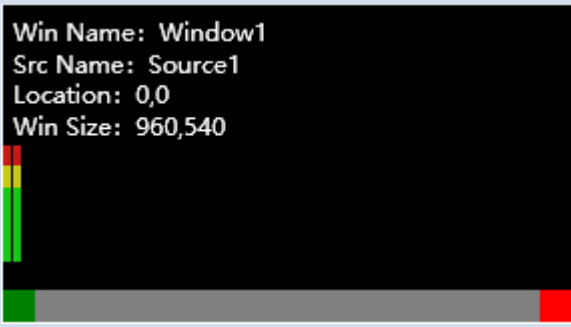
Use the tools to add rectangle window in working area, each kind of

drawing tool adds different type of element. Argos provides the following element type as shown in **Table 3.4-2**:

Table 3.4-2 The Element Type

Shortcut button	Element Type	Illustration
	Monitor	 <p>Win Name: Window1 Src Name: Source1 Location: 0,0 Win Size: 960,540</p>
	Analog Clock	
	Digital Clock	
	Countdown Clock	

■ Element Properties

The Properties are different for various elements.

Select an element in working area, its properties will be displayed in the Property Pane. For example, select an analog clock, its properties are as shown in Figure 3.4.20:

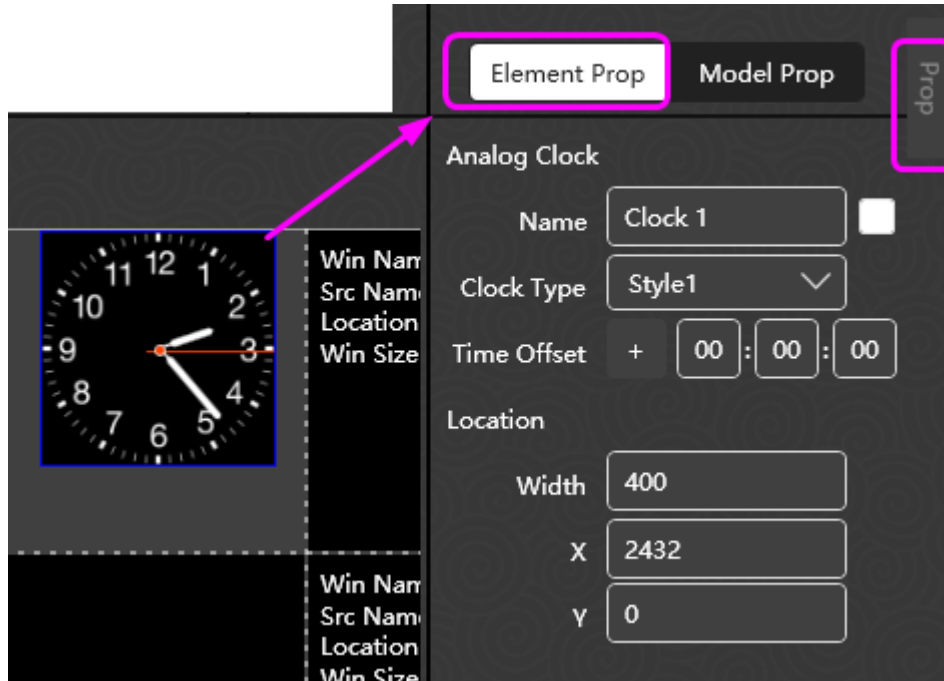

Figure 3.4.20 Element Properties

The property parameters are listed in Properties pane, click Element Prop tab to expand the parameter list.

3.4.3.1 Monitor

There are multiple tables for a monitor window in its property pane: **Appearance, View, Alarm, Border, Audio** and **UMD/TALLY**, the details are as below:

1. Window

The window properties contain the name, signal source, aspect ratio and OSD position parameters, as shown in **Figure 3.4.21**. The appearance is changing with the changes of the appearance properties.

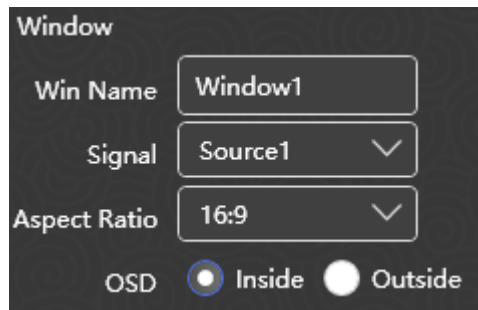

Figure 3.4.21 Appearance Properties

- Source Aspect Ratio

The Source Aspect Ratio parameter in video table is related with the Aspect Ratio parameter in Appearance table.

Example 1: when the Aspect Ratio parameter is set as 16:9 and the aspect ratio of the signal source is 4:3, the display is as shown in Figure 3.4.22:

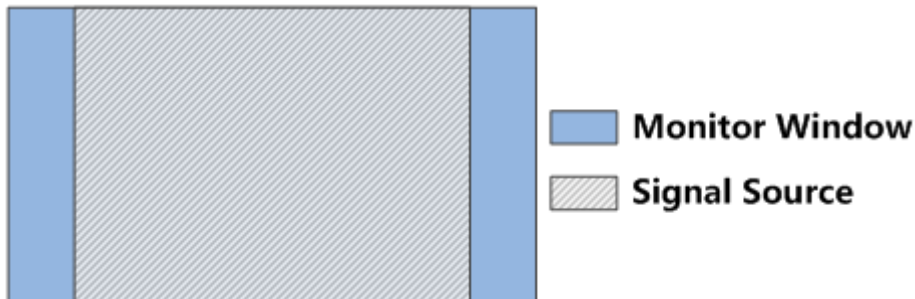

Figure 3.4.22 Example1 for Source Aspect Ratio Set

Example 2: when the Aspect Ratio parameter is set as 4:3 and the aspect ratio of the signal source is 16:9, the display is as shown in Figure 3.4.23:

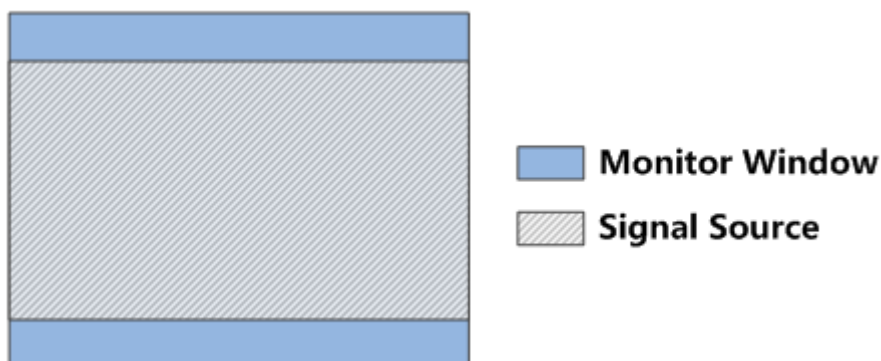

Figure 3.4.23 Example2 for Source Aspect Ratio Set

■ **Position of audio meter and UMD**

Set the position of audio meter and UMD by the OSD. If select Inside, audio meter and UMD will be displayed inside the Video Area of the monitor window, otherwise, If select Outside, audio meter and UMD will be displayed outside the Video Area of the monitor window, the comparison are as shown in Figure 3.4.24:

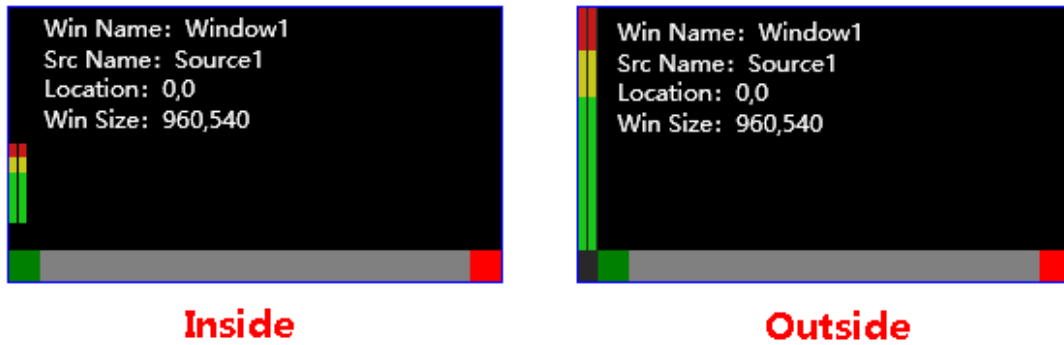

Figure 3.4.24 Position of Audio Meter and UMD

2. Border Related

The border related properties are used to set the border properties for the monitor display, as shown in Figure 3.4.25:



Figure 3.4.25 Border Properties

■ **Border Alarm**

The border alarm is used to give an alarm in the border of the monitor window with flash red color when meets the alarm condition.

The alarm condition for border alarm could be set as **Left Tally**, **Right Tally** or **Border Alarm Enable**.

- ❑ **Left Tally:** **Left Tally** refers to the left tally input detected from the signal source connected with monitor window;
- ❑ **Right Tally:** **Right Tally** refers to the right tally input detected from the signal source connected with monitor window;
- ❑ **Border Alarm Enable:** this item refers to three alarm display conditions in Alarm table below, including Video Loss, Video Black and Audio Loss. Any one of these conditions triggered will take this **Border Alarm Enable** item effect.

For example: as shown in Figure 3.4.26, set the **Border Alarm** as **Border Alarm Enable**, then if **Video Black** happened, the frame border will flash in red.

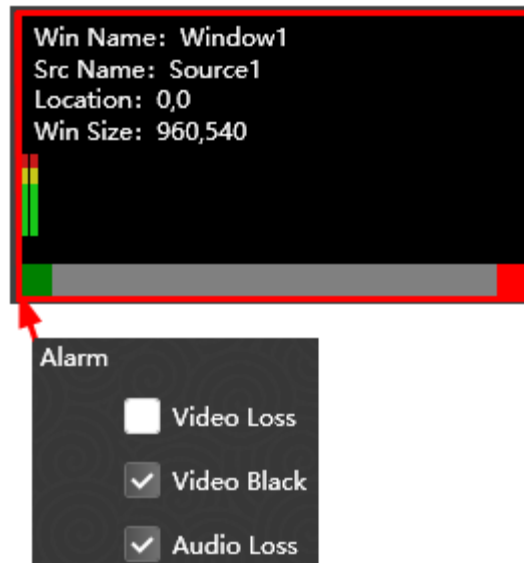

Figure 3.4.26 Border Alarm

Tips

- The **Border Alarm Enable** condition for **Border Alarm** has the top priority.
- The frequency of border blinking should be set in **Alarm Settings** → **Alarm Frequency** field in System page.

3. Switch

The switch properties express the display information for a monitor display, as shown in Figure 3.4.27:

Turn on or off the switch for border, left tally, right tally, UMD, audio meter, Followed source or marker in this table.



Figure 3.4.27 Switch Properties

- **TALLY and UMD**: it will display the left Tally indicator, the right Tally indicator and the UMD characters by ticking off Left Tally Enable, Right Tally Enable and UMD Enable, the background of UMD is gray, as shown in Figure 3.4.28:

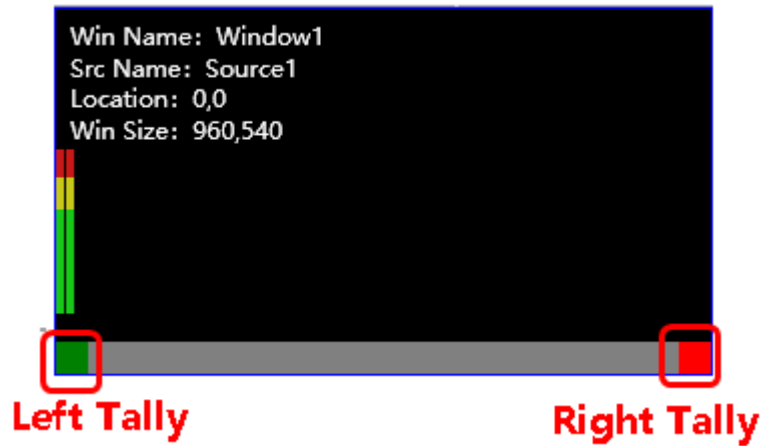

Figure 3.4.28 Tally and UMD

i Tips

- The precondition for the available of **Border Related** and **UMD Related** items are the selections of Border Enable, Left Tally Enable, Right Tally Enable and UMD Enable items in **Switch**.

4. UMD Related

The UMD Related properties express the UMD background color changing condition.

The alarm condition for UMD background color changing could be set as **Left Tally**, **Right Tally** or **Alarm** , as shown in Figure 3.4.29:



Figure 3.4.29 UMD Properties

- ❑ **Left Tally:** **Left Tally** refers to the left tally input detected from the signal source connected with monitor window, and the color of UMD background will be as the same as the left tally indicator;
- ❑ **Right Tally:** **Right Tally** refers to the right tally input detected from the signal source connected with monitor window, and the color of UMD background will be as the same as the right tally indicator;
- ❑ **Alarm:** this item refers to three alarm display conditions in Alarm table below, including Video Loss, Video Black and Audio Loss. Any one of these conditions triggered will take this **Alarm** item effect, then the color of UMD background will be red.

5. Alarm

The alarm properties express the settings whether to enable the alarm display on the monitor window when detecting the alarm events including video loss, video black or audio loss, as shown in **Figure 3.4.30**:

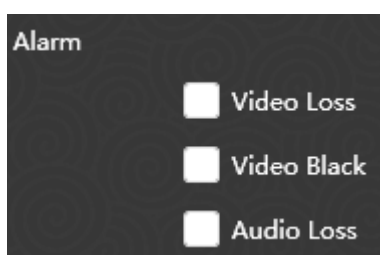

Figure 3.4.30 Alarm Properties

6. Location

The location properties express the size and position about monitor window, as shown in Figure 3.4.31:



Figure 3.4.31 Location Properties

Property name	Range	Default	Description
Window			
Win Name	--	Window*	Set the name for monitor

Property name	Range	Default	Description
Signal	--	Source1	Set the signal source for monitor
Aspect Ratio	16:9/4:3	16:9	Set the aspect ratio for monitor
OSD	Outside/Inside	Inside	Set the positions of UMD and audio meter relatively to the monitor frame.
Border			
Left Tally	Yes/No	No	Enable/disable the border alarm by Left Tally, the border will flash in the color of left tally indicator.
Right Tally	Yes/No	No	Enable/disable the border alarm by Right Tally, the border will flash in the color of right tally indicator.
Border Alarm Enable	Yes/No	No	Enable/disable the border alarm by video and audio alarm, the border will flash in red.
View			
Border Enable	Yes/No	No	Enable/disable the border display
Left Tally Enable	Yes/No	No	Enable/disable Left Tally display
Right Tally Enable	Yes/No	No	Enable/disable Right Tally display
UMD Enable	Yes/No	No	Enable/disable UMD display
Audio Meter Enable	Yes/No	No	Enable/disable Audio Meter display
Followed Source Enable	Yes/No	No	Enable/disable Followed Source function. Enable this item, the aspect ratio of the signal source will be consistent with the value of monitor window.
Marker Enable	Yes/No	No	Set whether to display marker for the monitor.
UMD Related			
Left Tally	Yes/No	No	Enable/disable the UMD alarm by Left Tally, the border will flash in the color of left tally indicator.
Right Tally	Yes/No	No	Enable/disable the UMD alarm by Right Tally, the border will flash in the color of right tally indicator.
Alarm	Yes/No	No	Enable/disable the UMD alarm by video and audio alarm, the border will flash in red.
Alarm			
Video Display Loss	Yes/No	No	Enable/disable video loss alarm information display on monitor window.
Video Display Black	Yes/No	No	Enable/disable video black alarm information display on monitor window.
Audio Enable Loss	Yes/No	No	Enable/disable audio loss alarm information display on monitor window.
Location			

Property name	Range	Default	Description
Width	-	0	Set the width for the monitor, the unit is pixel.
Height	-	0	Set the height for the monitor, the unit is pixel.
X	-	0	Set the starting x coordinate for the monitor, the unit is pixel.
Y	-	0	Set the starting y coordinate for the monitor, the unit is pixel.

7. Monitor Display

The monitor window displayed on the working area of Layout tab is as shown in **Figure 3.4.32**:

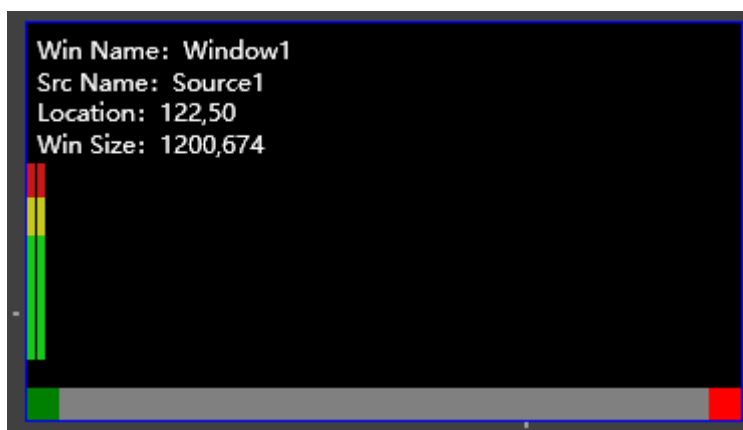

Figure 3.4.32 Position for a Monitor

The information listed in the monitor window from up to down contain: Win Name, Src Name, Location and Win Size, the details are as below:

- **Win Name**: it displays the name of this element. The default name is "Window" +"number", the number will be increased in sequence, not repetitive.
- **Src Name**: the signal source is showed in the monitor window followed the key word **Src Name** in working area.
- **Location**: it displays the location parameters X, Y, consistent with the Element properties in Location field.
- **Win Size**: it displays the location parameters Width, Height, consistent with the Element properties in Location field.

3.4.3.2 Clock/Date

The elements about date and time are contains the following types: **Analog Clock**, **Digital Clock** and **Countdown Clock**. The details are as below:

1. Analog Clock

The properties of analog clock are as shown in **Figure 3.4.33**:



Figure 3.4.33 Analog Clock Properties

The property items for analog clock are listed in the following table:

Property name	Range	Default	Description
Name	-	Clock1	Set name of the clock.
Clock Type	Style1/Style2	Style1	Set display type of the clock
Time Offset	-24~24	0	Set the offset for analog clock, the unit is hour.
Location			
Width	-	-	Set the Width for analog clock, it's a square.
X	-	0	Set the starting x coordinate for the clock, the unit is pixel.
Y	-	0	Set the starting y coordinate for the clock, the unit is pixel.

The appearance of analog clock is as shown in **Figure 3.4.34**:

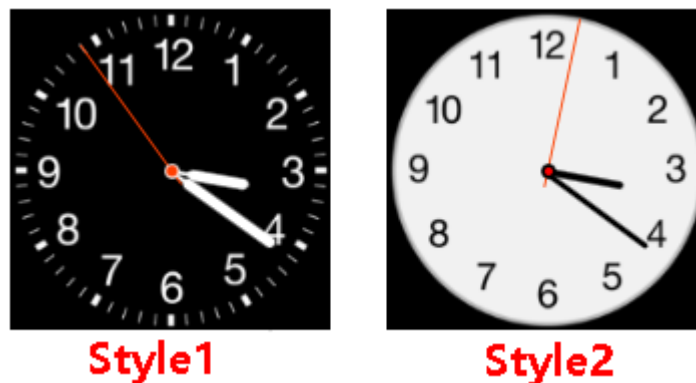

Figure 3.4.34 Analog Clock

i Tips

- The offset for analog clock could be set as a positive or negative number.

2. Digital Clock

The properties of digital clock are as shown in **Figure 3.4.35**:

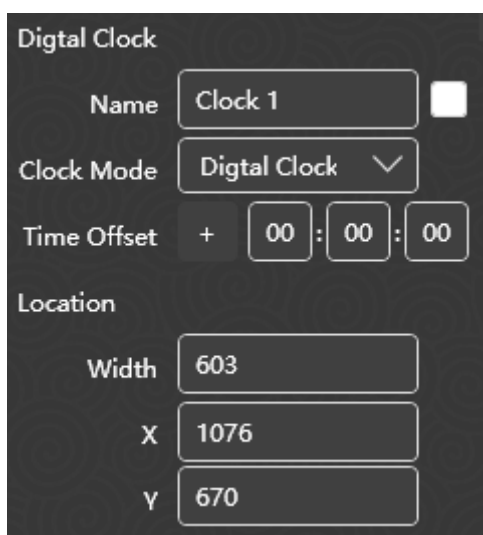

Figure 3.4.35 Digital Clock

The property items for digital clock are listed in the following table:

Property name	Range	Default	Description
Name	-	Clock1	Set name of the clock.
Clock Mode	Digital Clock/Date	Digital Clock	Set display type of the clock
Time Offset	-24~24	0	Set the offset for digital clock, the unit is hour.
Location			
Width	-	-	Set the Width for digital clock.
X	-	0	Set the starting x coordinate for the clock, the unit is pixel.
Y	-	0	Set the starting y coordinate for the clock, the unit is pixel.

The appearance of digital clock is as shown in **Figure 3.4.36**:



Figure 3.4.36 Digital Clock

3. Countdown Clock

The properties of countdown clock are as shown in Figure 3.4.37:

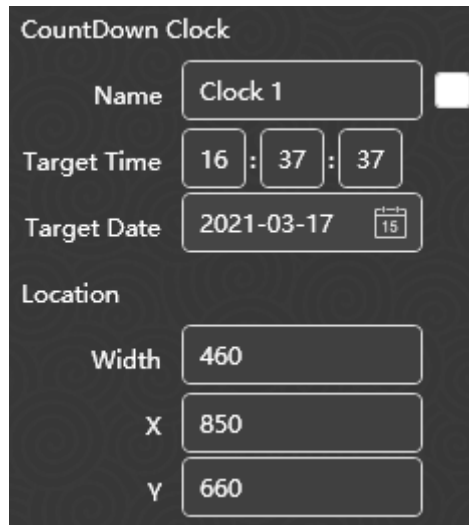

Figure 3.4.37 Countdown Clock

The property items for digital clock are listed in the following table:

Property name	Range	Default	Description
Name	-	Clock1	Set name of the clock, and tick off this item or not to display the clock name.
Target Time	HH:MM:SS	Current time	Set the terminal time of the countdown clock
Target Date	YYYY:MM:DD	Current date	Set the terminal date of the countdown clock
Location			
Width	-	-	Set the Width for countdown clock.
X	-	0	Set the starting x coordinate for the clock, the unit is pixel.
Y	-	0	Set the starting y coordinate for the clock, the unit is pixel.

The appearance of countdown clock is as shown in **Figure 3.4.38**:

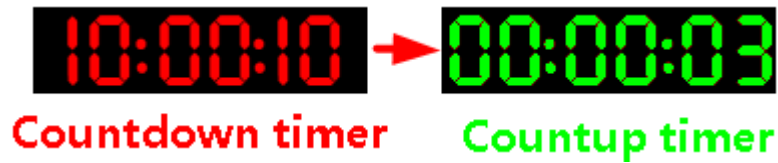

Figure 3.4.38 Count Timer

Tips

- The countdown timer will count down in red until it reaches the target time and date, from then on, it will count up in green .

As above, all kinds of elements have the following two properties:

- **Horizontal Start Position:** the starting x coordinate of the left corner of the element window;
- **Vertical Start Position:** the starting y coordinate of the left corner of the element window.

Take a monitor element for example, the coordinate of the left corner is as shown in **Figure 3.4.39**:

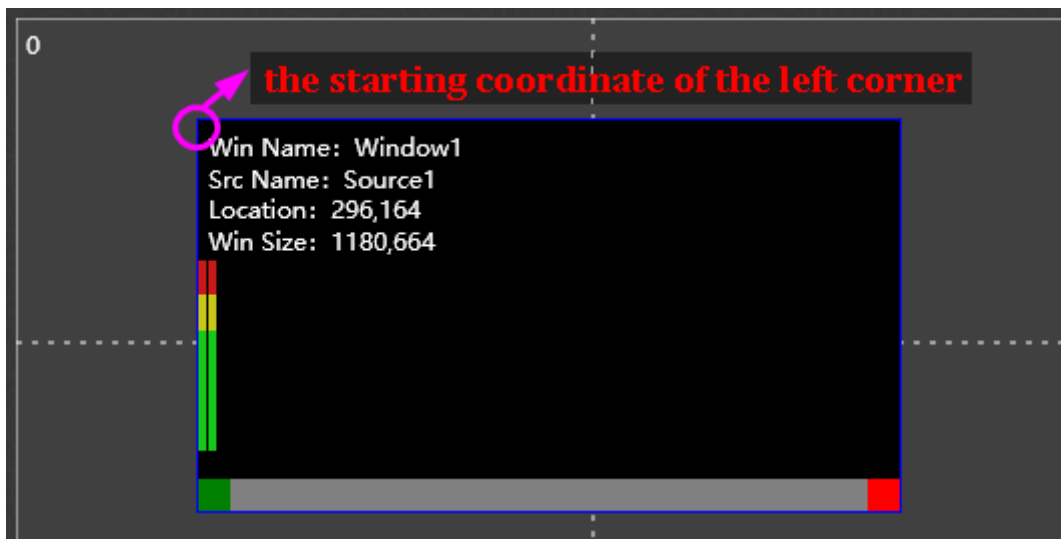

Figure 3.4.39 Left Corner for a Monitor Element

Property Modification

The element will be changed right after you have modified its properties in working area, and the property value will be changed right after you have moved, stretched or zoomed the element, and the position and size of an element will change with the properties, too.

i Tips

- The parameter value of the **X** and **Y** will determine the starting coordinate of an element window.

3.4.4 Elements Layout

It will introduce the application of the tools in layout configuration, and give some examples for impressive comprehension.

First, create a template, as shown in Figure 3.4.40, then, we will add some elements to describe how to configure a layout for a template.

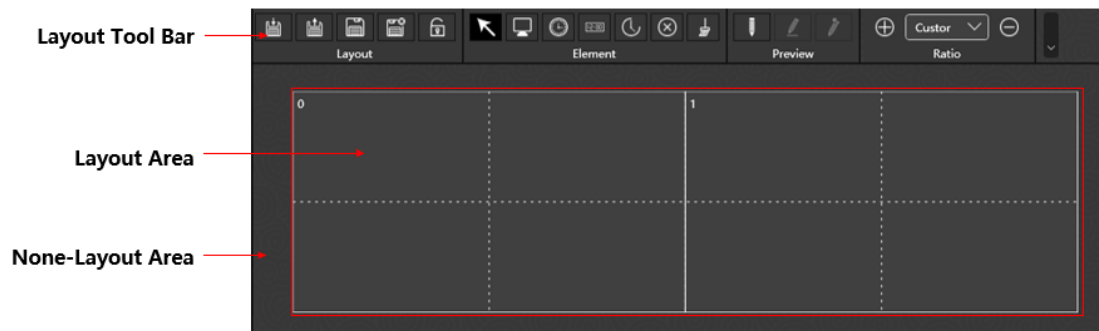

Figure 3.4.40 Working Area for Layout Configuration

- **Layout Area:** all elements will be added and displayed in this area, and the physical video walls are corresponding to this area which is the light gray area in working area for layout configuration.
- **None-layout Area:** no element can be added or displayed in this area, and this area has no relationship with the physical video walls, it is the canvas for the layout area and surrounding it.

When the mouse cursor is in layout area, and select some element windows, you can cooperate with tool buttons to activate the corresponding commands, the following will introduce these tools.

3.4.4.1 Add an Element Window

Take the monitor window for example, add a monitor window in the layout area, the others are the same.

- **Use element tool to add an element window**

Operation: click the monitor tool button , now you have chosen the monitor tool.

- **Element with any size:** click the left mouse button to decide the starting coordinate of the top left corner, hold the button down and draw a rectangle, then release the left mouse button, it will add a monitor window, as shown in **Figure 3.4.41**:

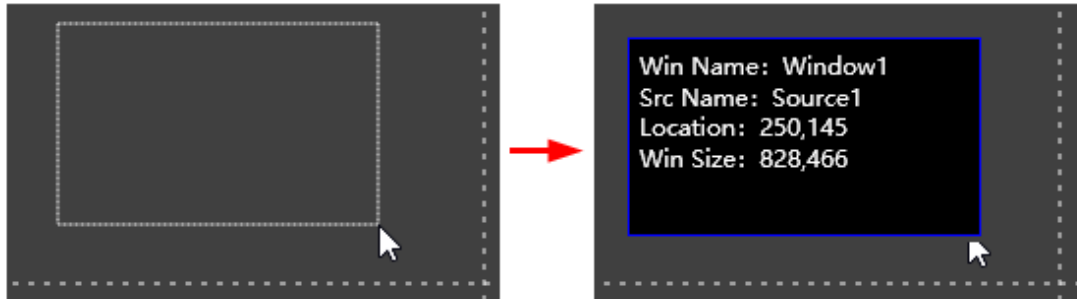



Figure 3.4.41 Add a Monitor Window

- **Element with accurate size:** first use the monitor tool  to add a monitor window, then click to select the element window in working area, it will display its properties about size and position in its **Element Prop** pane, modify these properties values to determine the accurate size and position for this window in video wall.

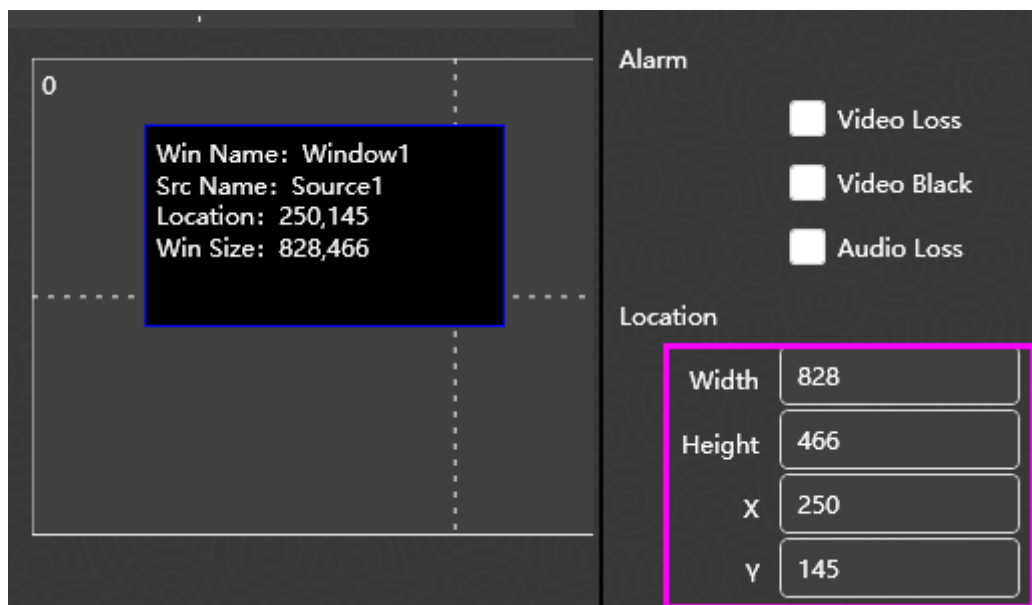



Figure 3.4.42 Location Properties for a Monitor Window

Tips

- After you have selected an element tool button, press and drag to add

element windows consecutively, you will add the same kind of element until you select another element tool.

- Especially, the outline of an analog clock is a square, the ratio of the width and the height is 1.
- It is recommended not to overlap the element windows on a video wall, in case of the display effects, there will be an icon  on each overlapped element window as prompt in layout area, and there will be a tip at the mouse cursor on the overlapped elements.

■ **Use split tool to add an element window**

Especially, after add a monitor window, right click the monitor to select the split command to divide the selected monitor into the desired numbers, refer to "3.4.4.3 Split" for details.

3.4.4.2 Select an Element Window

You can select only one element window, or multiple element windows, or all of the element windows in working area at a time.

Tips

- **Select tool:** click the select tool button in the tool bar , it will change its background color when it is chosen.
- **Mouse cursor:** after select a tool button, click in the layout area, and it will focus the mouse cursor into the layout area, make sure you have move the mouse cursor into the layout area before you perform the selection operation.

- **Select a single element window:** click the Select tool  in edit tool bar, and click on your desired element window, it will show a red rectangle surrounding the selected element window, and there are adjusting handles (white rectangle) on the element window, thus this element window is selected, as shown in **Figure 3.4.43**

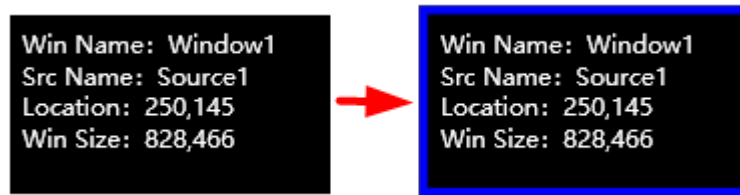

Figure 3.4.43 Single Selected Element Window

- Cancel Selection:** when there are selected element windows in working area, click in the blank position in layout area, or draw another element window, the selection will be canceled.

3.4.4.3 Split

- Split**

Use split command to add multiple monitor windows with the same size.

Draw a big enough monitor window, right click it and select **Split** command, it will pop up a setting window, enter the split parameters in **Row** and **Col** field, and set the align mode to be **Top/left** or **Center**, as shown in **Figure 3.4.44**, then it will be split into a few small windows with the same size, as shown in **Figure 3.4.45**:

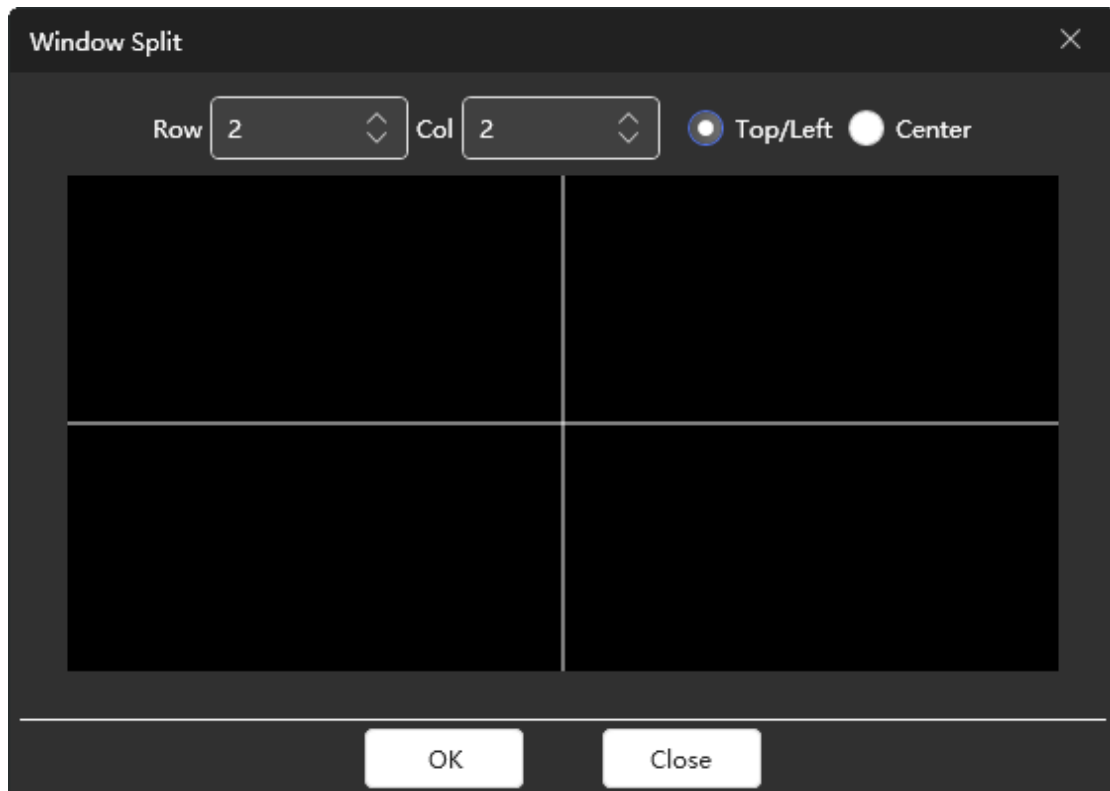

Figure 3.4.44 Split Setting

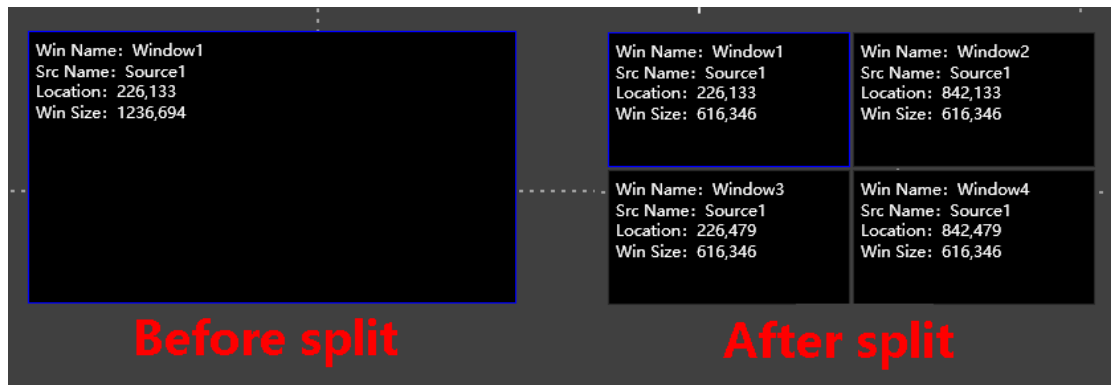

Figure 3.4.45 Split the Selected Element Window



i Tips

- Usually, when need to add equal sized monitors, using the split tool will be very convenient.

3.4.4.4 Adjust Window

1. Adjust the Window Size

The element added in layout area is display as a rectangle window, and the size of the window is decided by the height and width of the element.

- **Stretch an element:** select an element, and move the mouse cursor to the edge of the window, the cursor will change its shape into a double-headed arrow like this: ,  or , then press the left mouse button down, and drag it to be zoomed in or zoomed out, thus to change the size of the window, as shown in **Figure 3.4.46**:

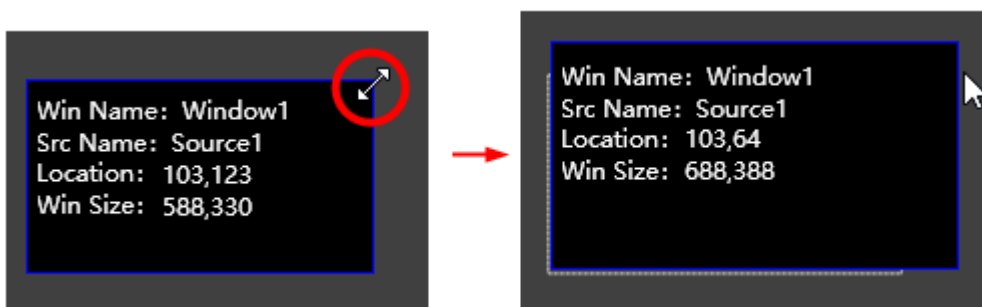

Figure 3.4.46 Stretch the Window

Stretch a window to change its height and width, or modify the values of the properties on height and width to change the size.

Tips

- The ratio of the element window can be set at 4:3, or 16:9 in the **Aspect Ratio** property.

2. Maximize

Right click on the element window, it will display the context menu list, as shown in Figure 3.4.47:

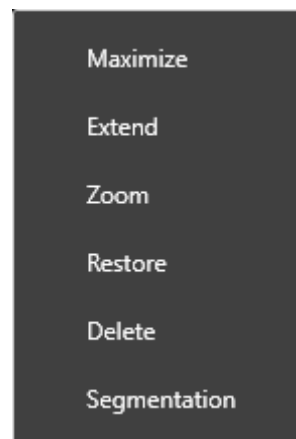

Figure 3.4.47 Context Menu of Element Window

Click Maximize command, the element window will be zoom in to fulfill the whole canvas, as shown in Figure 3.4.48:

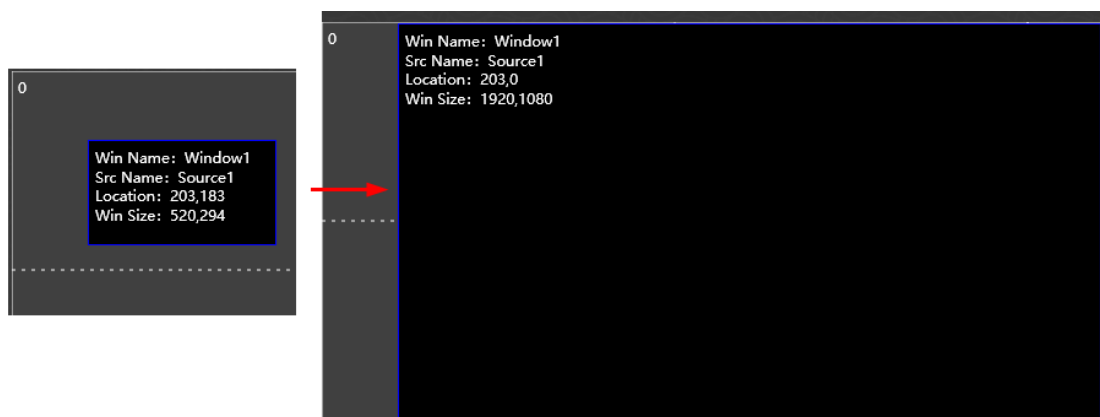

Figure 3.4.48 Illustration for Maximize Element Window

Tips

- The maximize, extend, zoom, restore command will has no effect on the

original aspect ratio of the element window.

- The maximize size of the window will not exceed 2560 X 1440.

3. Extend

Click Extend command after drawing an element, the window will align and extend to the nearest grid where the original window is most closed to, as shown in Figure 3.4.49:

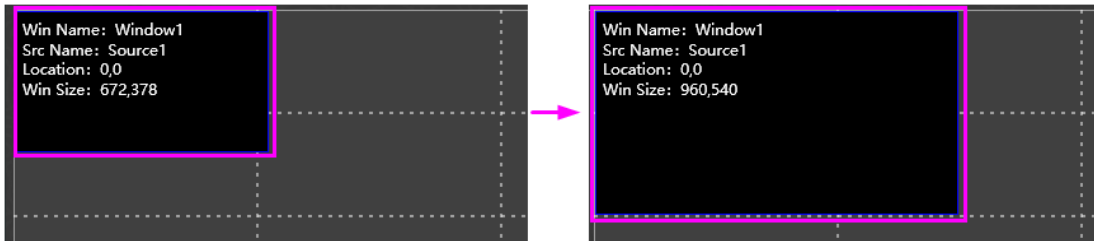

Figure 3.4.49 Illustration for Extend

i Tips

- Collaborate with the Screen Split parameters in Model prop pane, you can use the extend command to move the window very conveniently to align with the grid.

4. Zoom

Click Zoom command after drawing an element, you can see the window will zoom and align to a grid whose geometric center of the old element window is in, as shown in Figure 3.4.50:

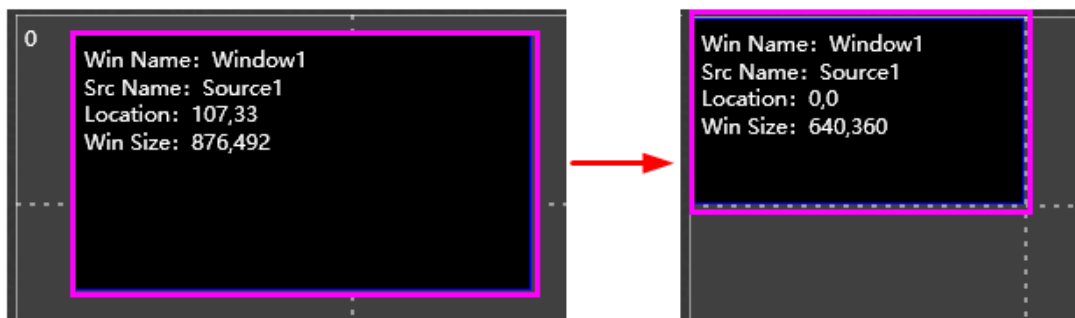

Figure 3.4.50 Illustration for Zoom

Tips

- Zoom command is related to the alignment of the grid lines in the canvas.
-

5. Restore

After maximize, extend, move or zoom operations, click Restore command, you can restore the size of element window to the original size and location. Only one step to one step.

6. Adjust the Window Position

The element added in layout area is display as a rectangle window, and the position of the window is decided by the **Horizontal Start Position** and the **Vertical Start Position** of the element. Move the element window as the following methods:

- **Method 1:** select an element window, press the left mouse button down, and drag it to the desired position, and the coordinate of the window will be changed.
- **Method 2:** modify the values of the X property and Y property of the element, then the position will be changed.

Tips

- The dotted line is very helpful when moving the element window and aligning it to this white dotted line on the video wall.
-

3.4.4.5 Common Edit Operation

1. Copy and Paste for Element

You could copy and paste an element in working area in Layout configuration window. The operations are as below:

Click to select an element window as the original one, and use **Ctrl+C** as the shortcut for Copy on keyboard, and click on the layout area to set the coordinate of the left corner for the new window, then use **Ctrl+V** as the shortcut for **Paste**, thus, the new element window will be pasted at the new position.

For example: the top left corner of the original monitor window is (226,133), copy it, and paste it, the top left corner of the new monitor is (826,580), as shown in **Figure 3.4.51**, the new one will be located to the coordinate you have clicked on the layout area.

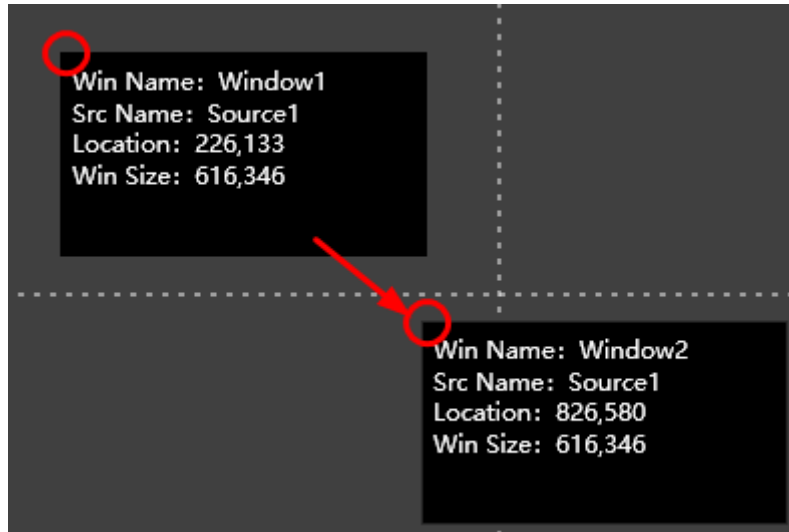





Figure 3.4.51 Copy and Paste

2. Delete Element

You can delete element by the following methods:

- Method 1: Use the Delete command. Click **Delete** button  in tool bar, it will delete the selected elements in working area.
- Method 2: Use the Clear command. Click **Clear** button  in tool bar, it will delete all elements whether selected or not in working area.
- Method 3: Use the key. Click to select an element, then press **Delete** key to delete the selected element.
- Method 4: Use the context command. Right click an element, and select the Delete command in the right-click menu to delete the selected element.

Tips

- Use Delete key to delete the selected elements.
 - All of the above deletion can be canceled by Undo  command.
-

3. Overlap

When the monitor windows overlap, there will be an overlap icon  on each overlapped monitor window, and move the window to remove the overlap icon.

3.5 Other Functions

It will introduce some assistant function in ARGOS, such as **Restore Factory Default**, **Hardware Update**, **Software Info** and **Language Selection**.

3.5.1 Restore Factory Default

Use the Factory command to restore the factory defaults.

Click **Factory** button , it will pop up the prompt for confirming whether to restore the factory defaults, as shown in **Figure 3.5.1**.

Click **OK** to restore the factory defaults, then restart the multi-image processor. Click **No** to cancel the restore operation.

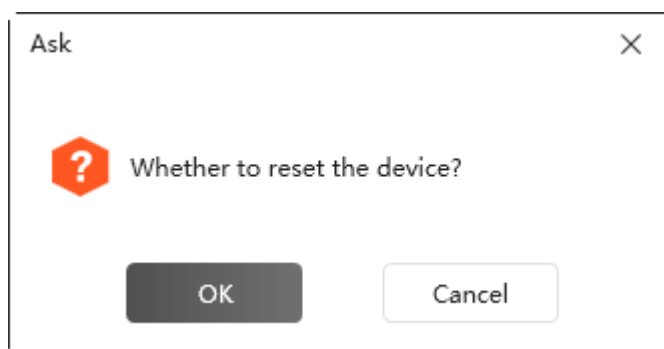

Figure 3.5.1 Prompt for Restore Factory Default

Tips

- The restore factory default operation will not restore the default IP address, mask, gateway and alarm log information.
 - The restore factory default operation is only available in device online status.
-

3.5.2 Language

Use Language command to switch language between English and Chinese in the software.

Click User→ **Language** button in title bar, it will pop up Soft Language dialog box, as shown in Figure 3.5.2, click the drop down list for language selection: **Chinese**, **English**, choose one and click **OK** to confirm the

modification, and restart the software. Then the software language will be changed to the corresponding language item.

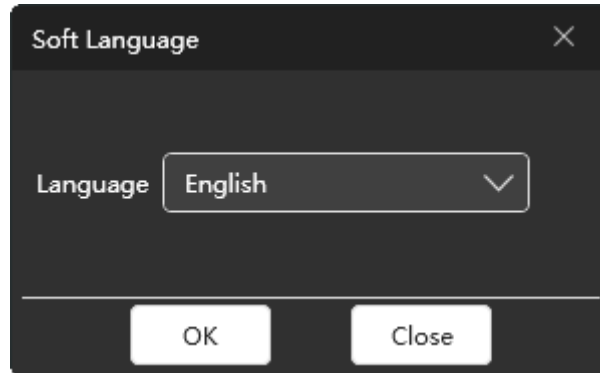

Figure 3.5.2 Change Language Dialog Box

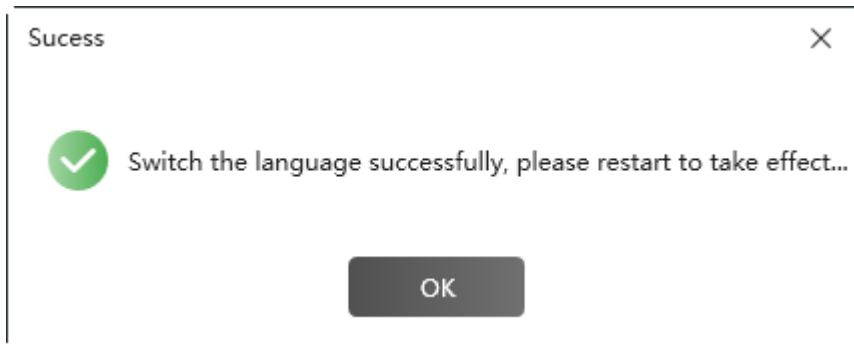



Figure 3.5.3 Change Language Dialog Box

Warning

- Please restart the software to take the language switch effect.

3.5.3 Hardware Update

Click **Firmware** button  in system page to update firmware for the selected device. Argos software supports update operation only with the file of bin type.

The update operations are as following instructions:

Step 1 Select the update file

Click **Firmware** command, it will pop up firmware dialog box, as shown in **Figure 3.5.4**, click **Select** button in Firmware Update area to select an update file, it will pop up the Select File dialog box, as shown in Figure 3.5.5, click **Open** button to load this file.

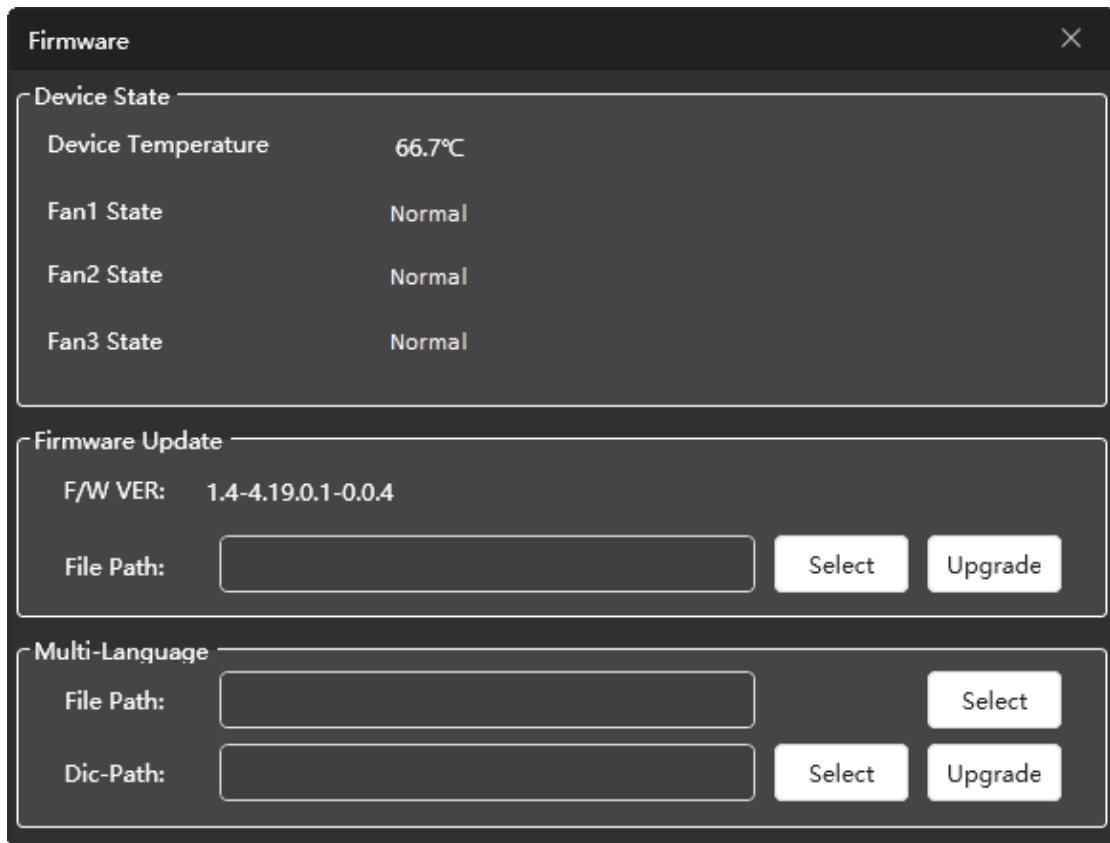

Figure 3.5.4 Update Dialog Box

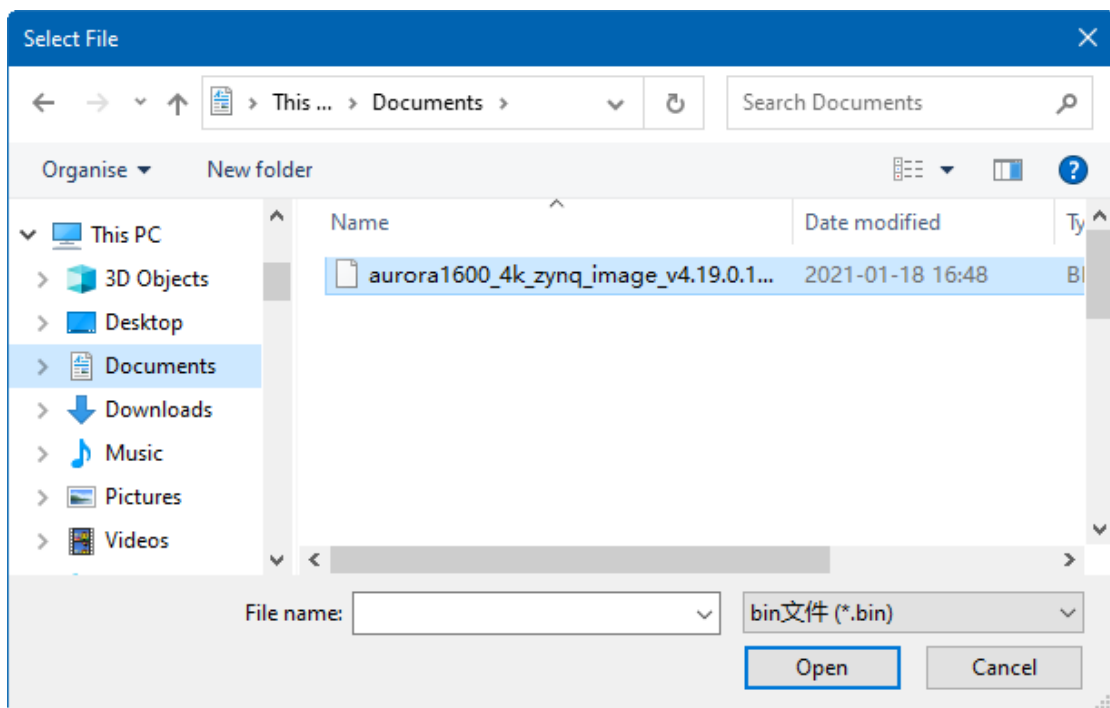

Figure 3.5.5 Select File Dialog Box

Step 2 Update and Restart

It will display the name of the update file in the file path field, then click **Update** button to confirm the upgrade operation, it will display the process of the update, as shown in **Figure 3.5.6**:

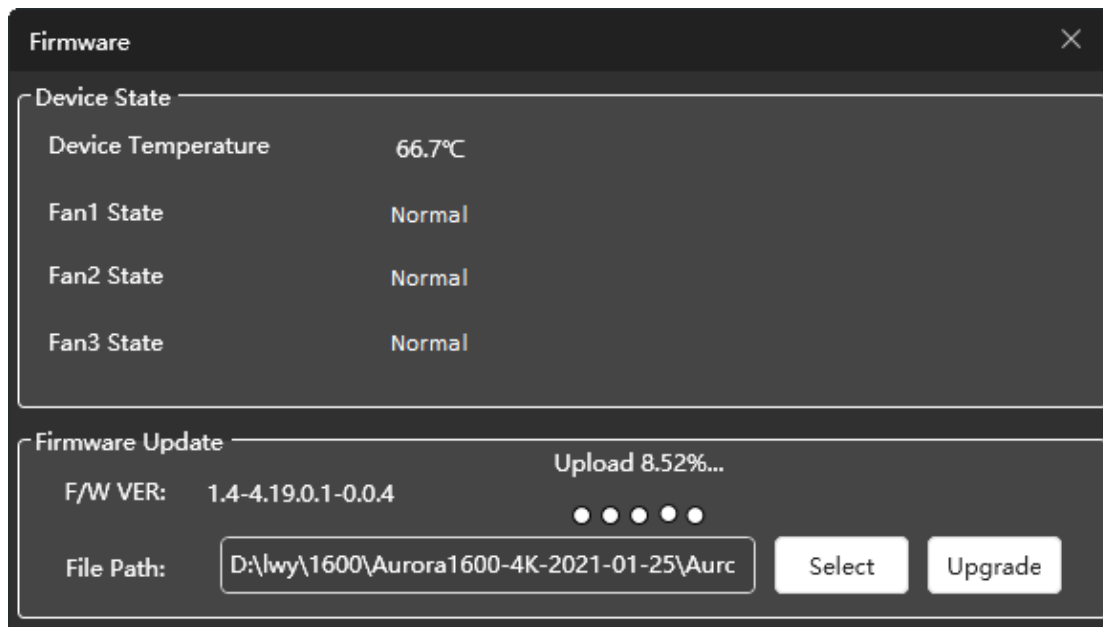

Figure 3.5.6 Update Dialog Box

After update operation has completed, it will pop up a restart prompt as shown in **Figure 3.5.7**, click **OK** button, and please restart your device manually to effect the update operation.

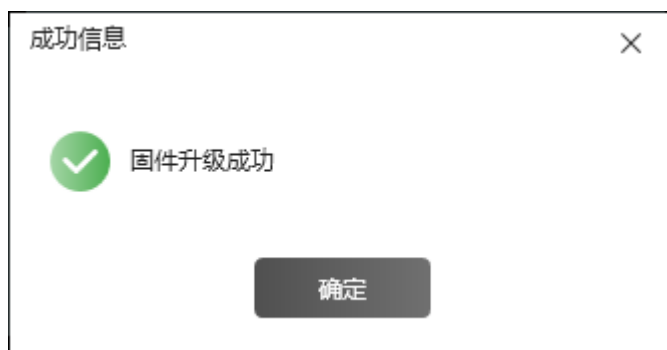

Figure 3.5.7 Restart Prompt

Tips

- It is recommended that the connection between the control computer and the target multi-image processor should be straight through connected.
- When update the multi-image processor, after the prompt of updating

completed, please power off the device and restart it again to affect the update.

3.5.4 About

Use the **About** command to display the basic and version information about this software.

Click user **About** menu command in the title bar, it will pop up the version information dialog box, as shown in **Figure 3.5.8**, click **Close** button  to close this dialog box.



Figure 3.5.8 Update Dialog Box

3.6 Linkage With the Supervisory Monitor

Argos system could set up a linkage with LMW-550-SE supervisory monitor through SDI interface, the connection is as shown in Figure 3.6.1:

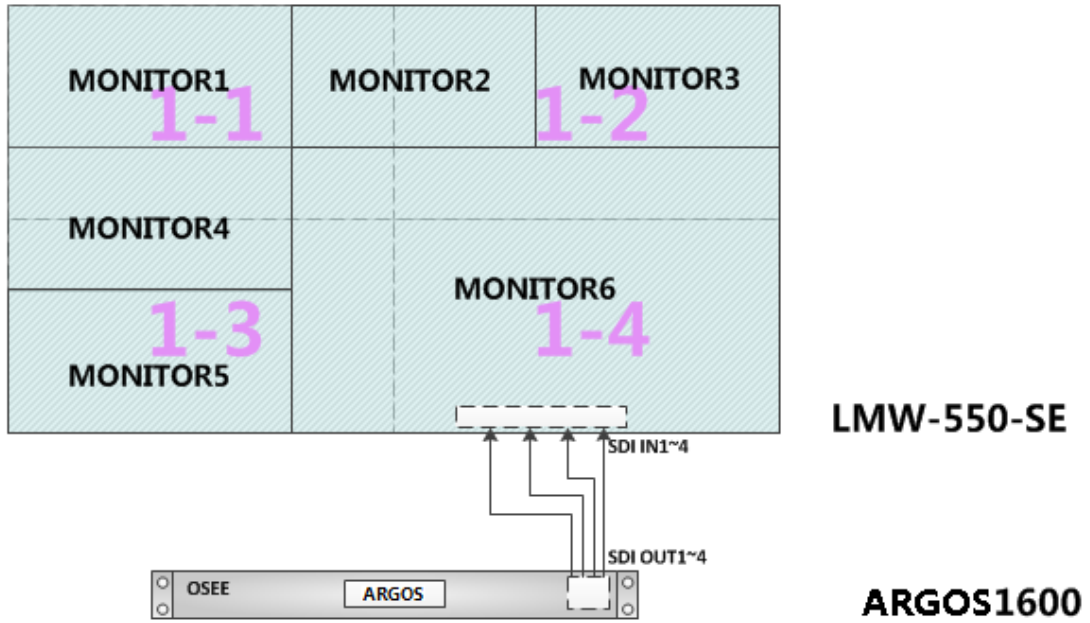

Figure 3.6.1 Linkage Between Argos and Supervisory Monitor

-----No Text Below-----



FOR MORE INFORMATION PLEASE VISIT: <http://www.osee-dig.com/>
OSEE TECHNOLOGY LTD.
No.22 Building, No.68 zone, Beiqing Road, Haidian District, Beijing, China
Tel: (+86) 010-62434168, Fax: (+86) 010-62434169
E-mail: sales@osee-dig.com